

SINGER
992E5,E11

107084
 107178
 107625
 80(429)
 91(888)
 17(803)
 off 2102

107085(429)

107178
 107625
 80(430)
 91(888)
 17(803)
 164157
 off 2102

107086(430)

107084
 107178
 107625
 80(431)
 91(888)
 17(803)
 off 2102

107085(431)

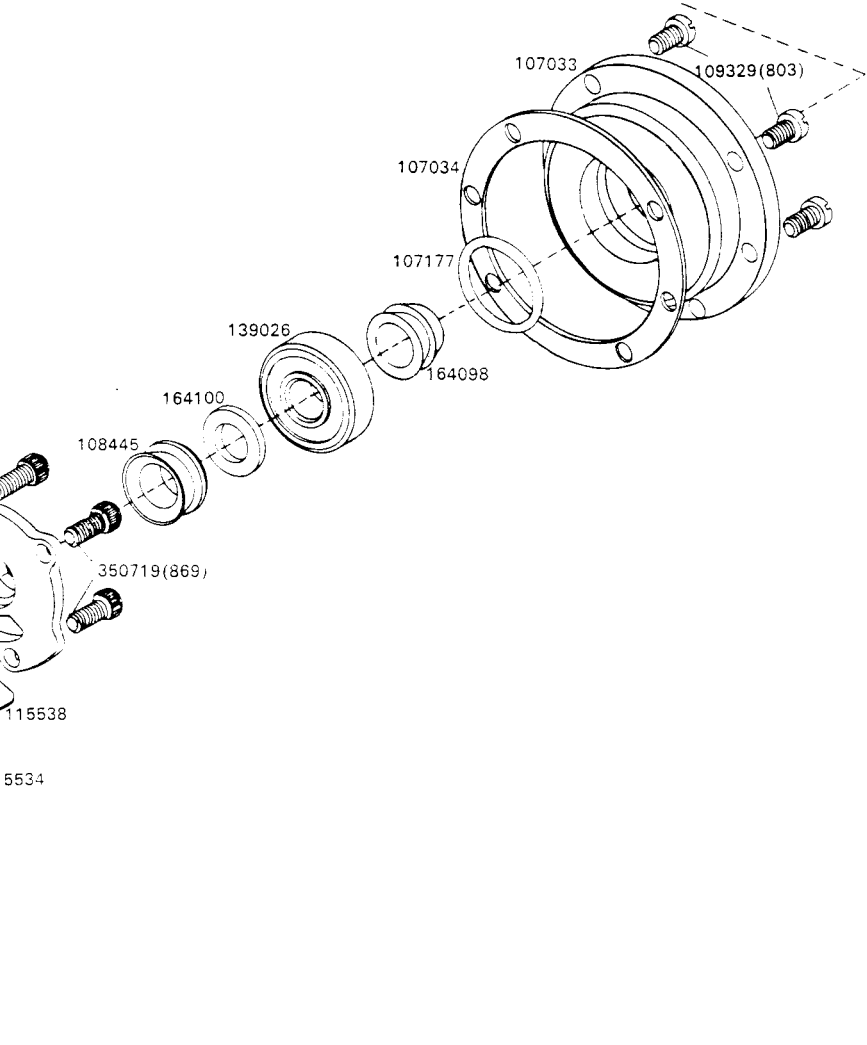
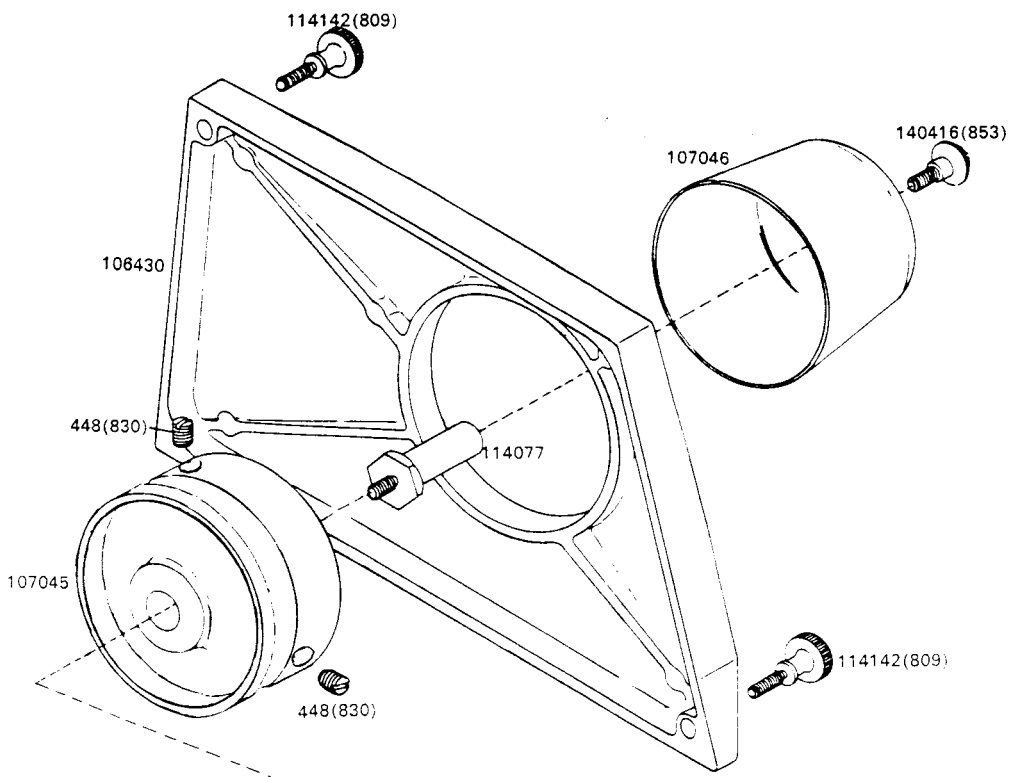

CHAIN CUTTER RETRO-FIT KIT NO. 117028

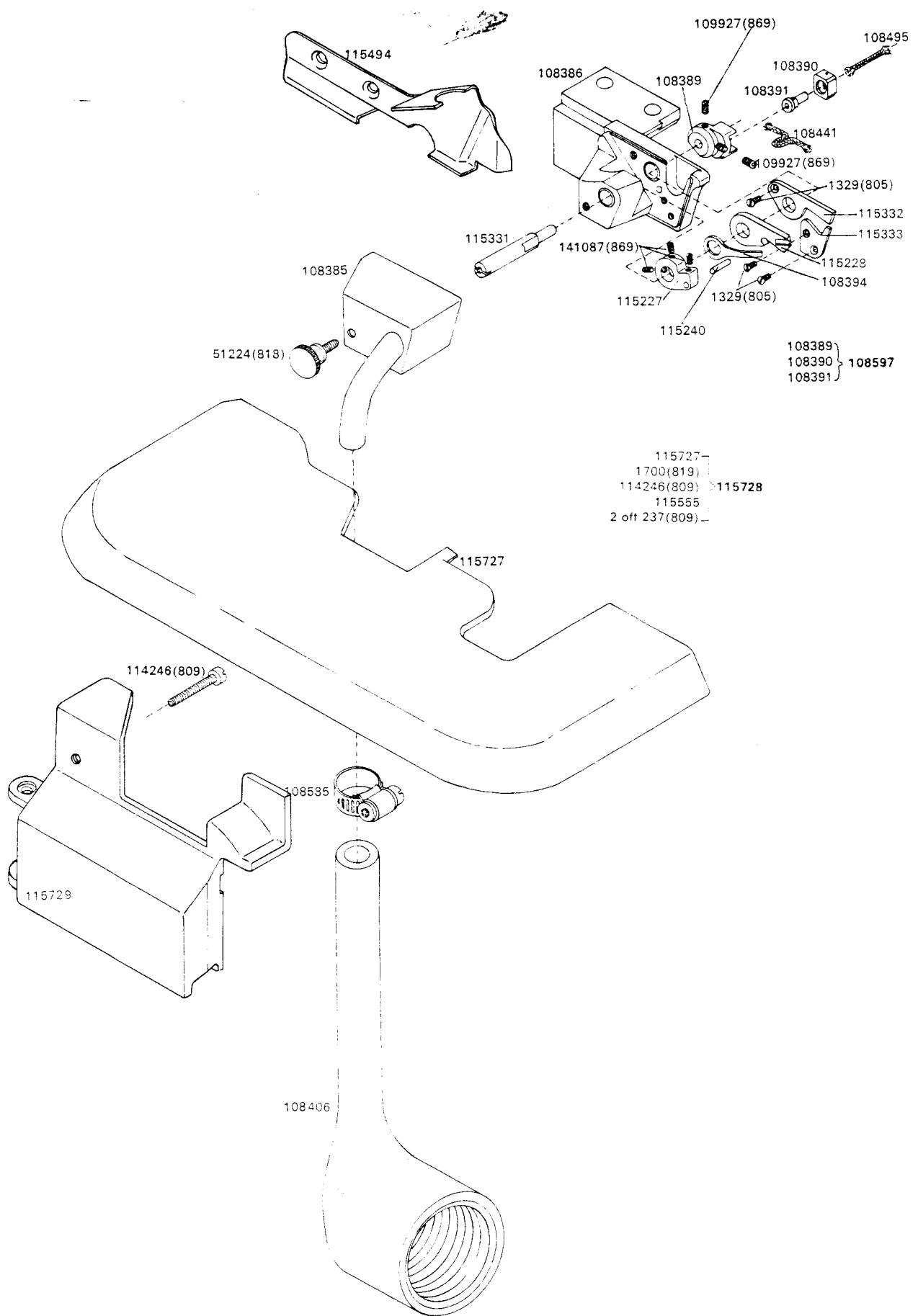

- 108389
- 108390 } 108597
- 108391 }

- 115727
- 1700(819)
- 114246(809) } 115728
- 115555
- 2 off 237(809)

1

2

3

4

115515
 1700(809)
 114246(809) 115586
 115555
 2 off 237(809)

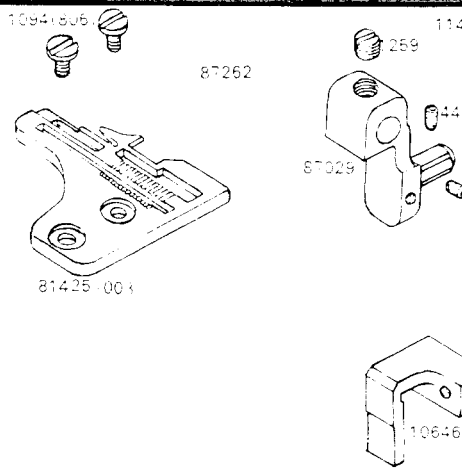

5

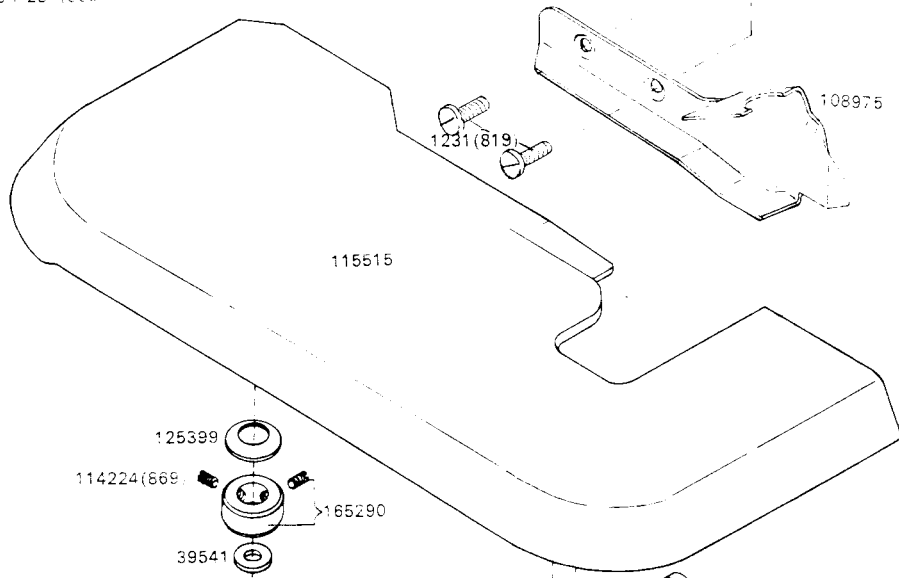

6

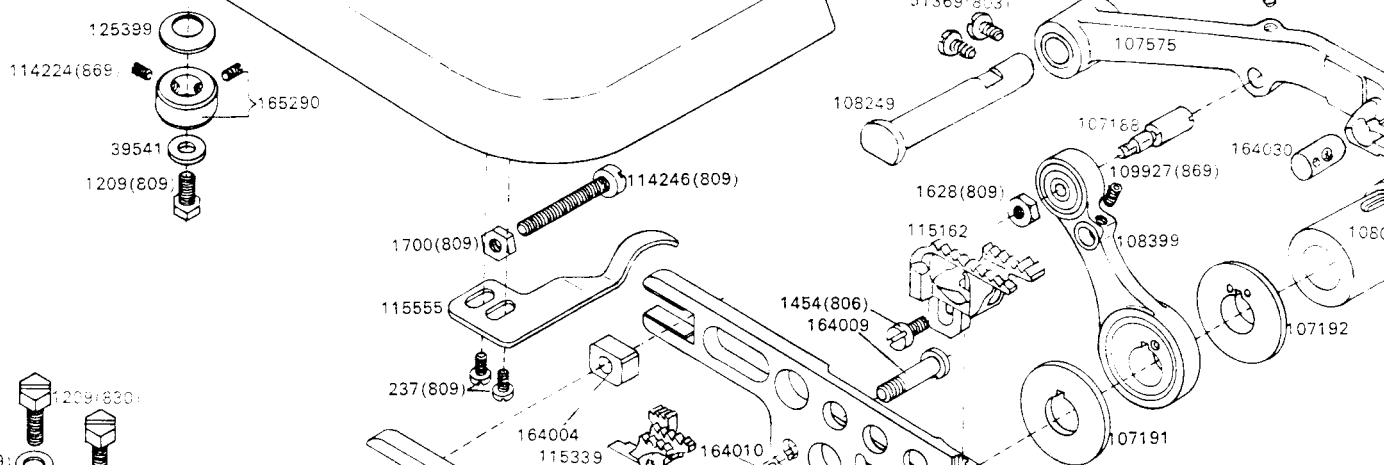

7

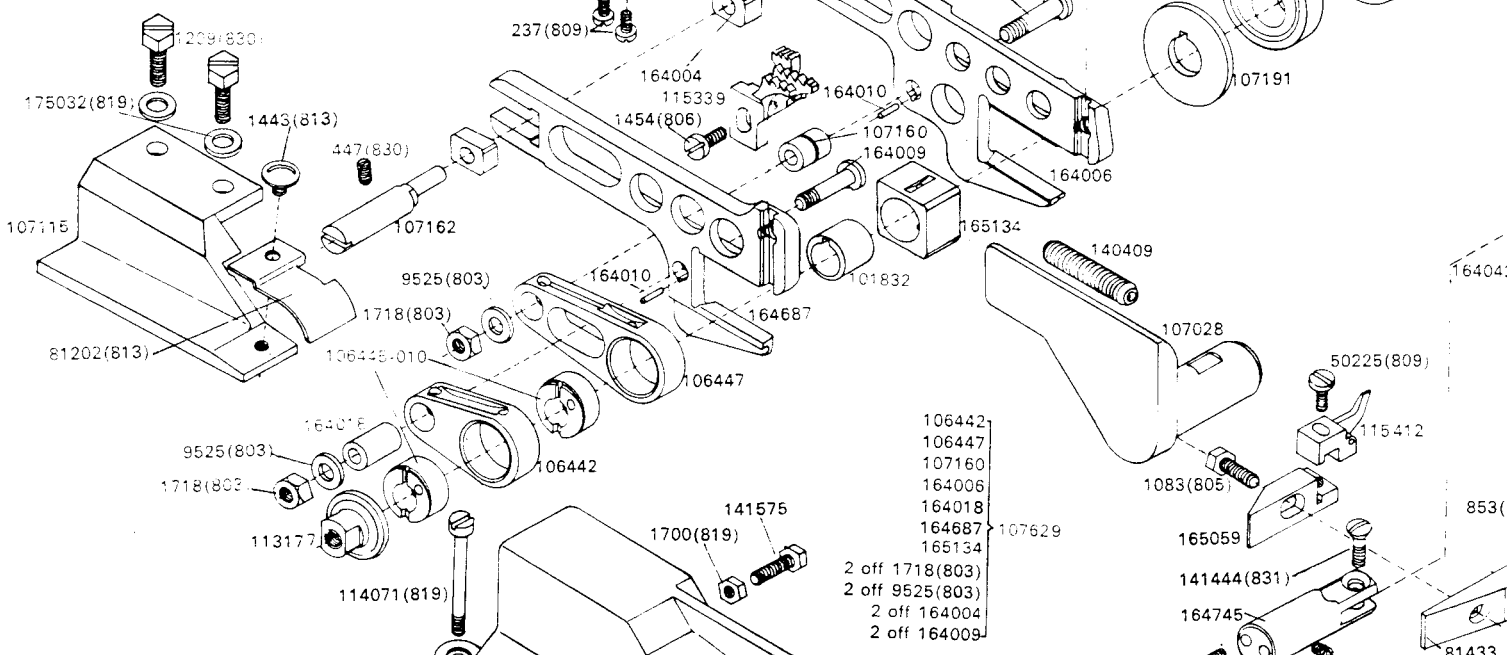

8

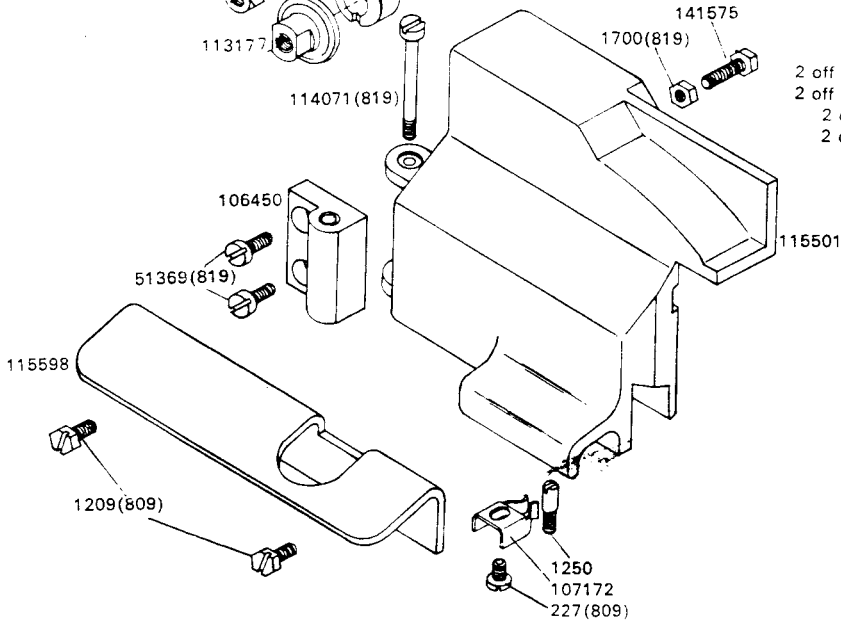

A

B

C

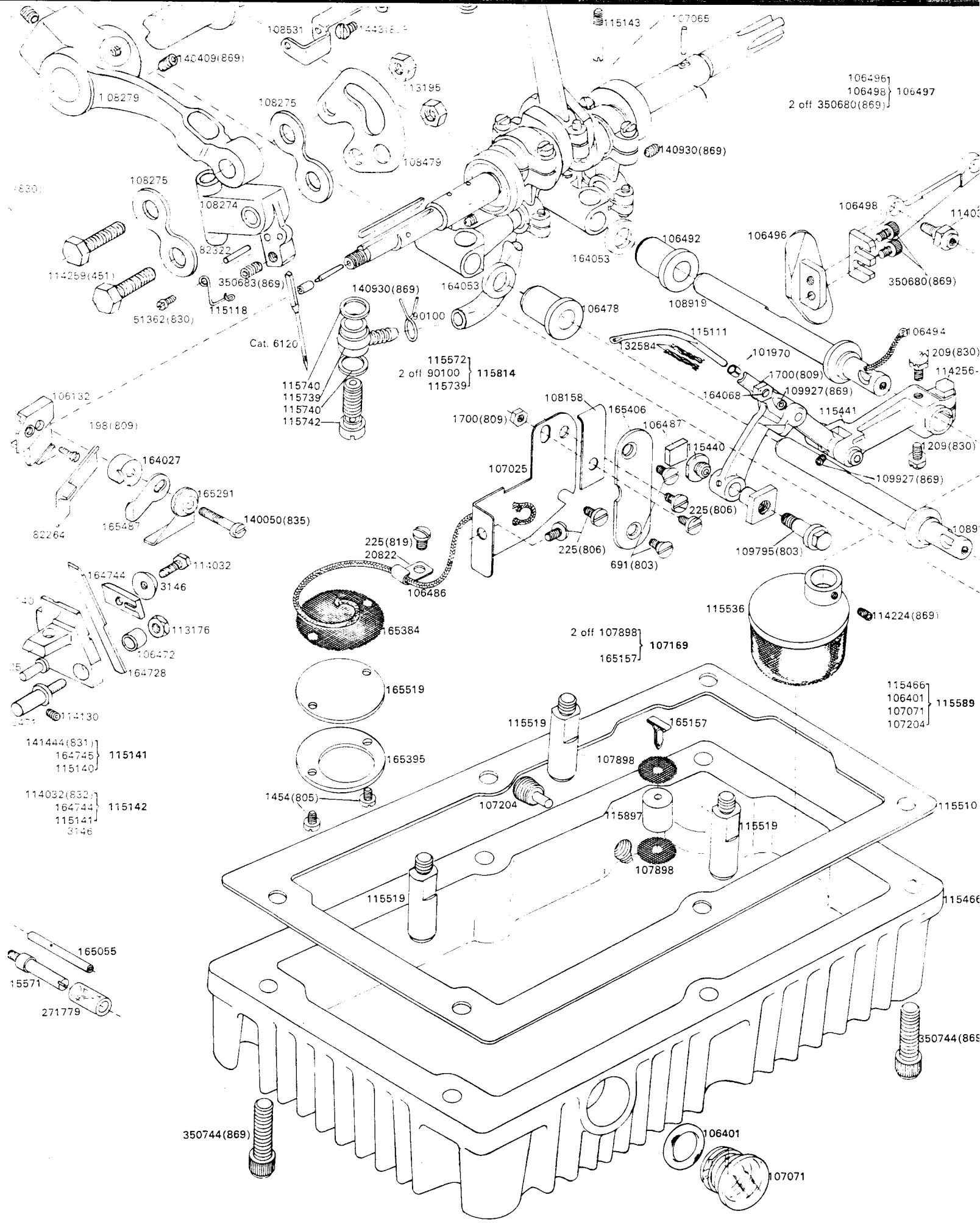

D

E

F

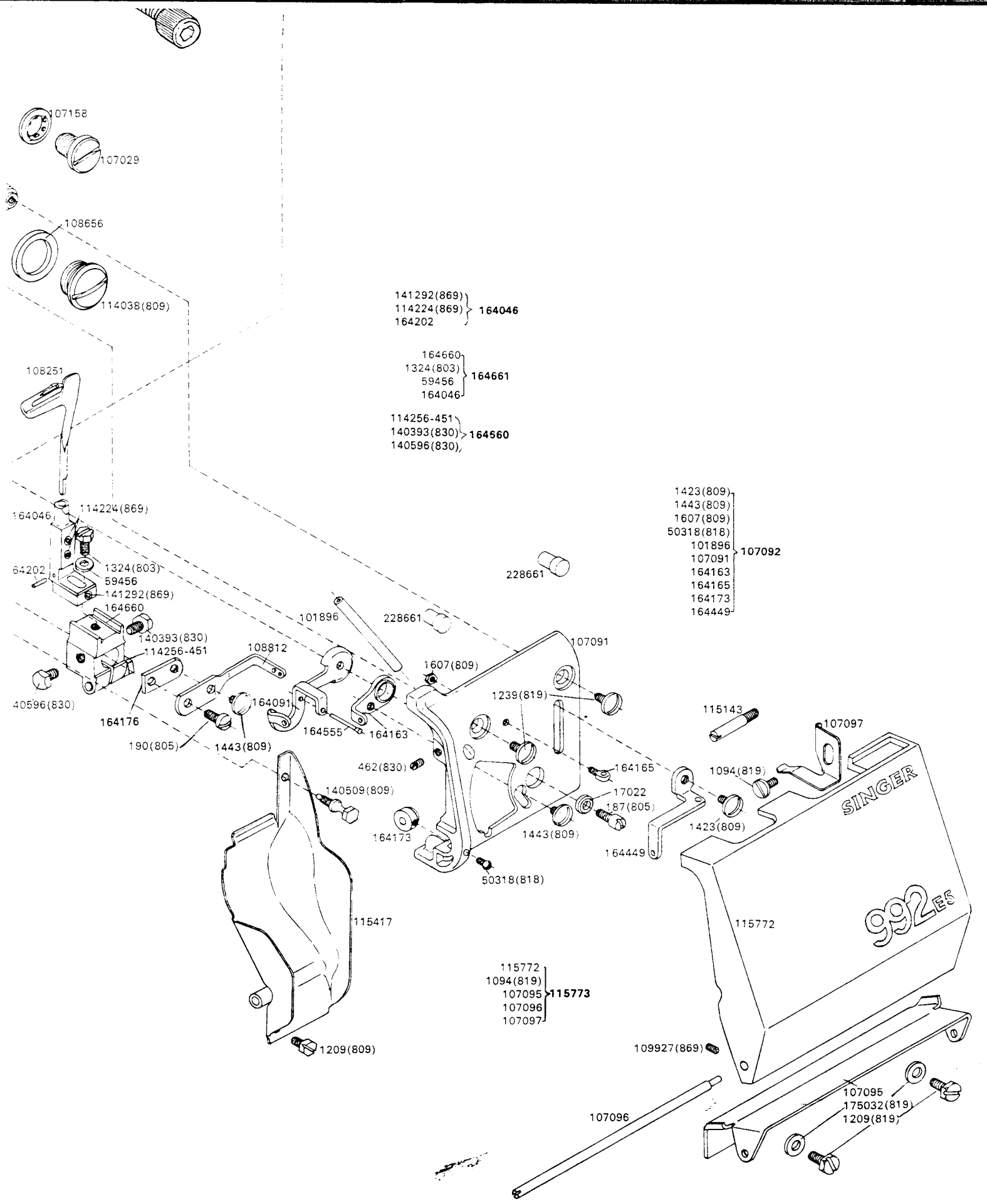

141292(869)
 114224(869) } 164046
 164202

164660
 1324(803)
 59456 } 164661
 164046

114256-451
 140393(830) } 164560
 140596(830)

1423(809)
 1443(809)
 1607(809)
 50318(818)
 101896
 107091 } 107092
 164163
 164165
 164173
 164449

115772
 1094(819)
 107095 } 115773
 107096
 107097

107095
 175032(819)
 1209(819)

ACCESSORIES (NOT TO SCALE)

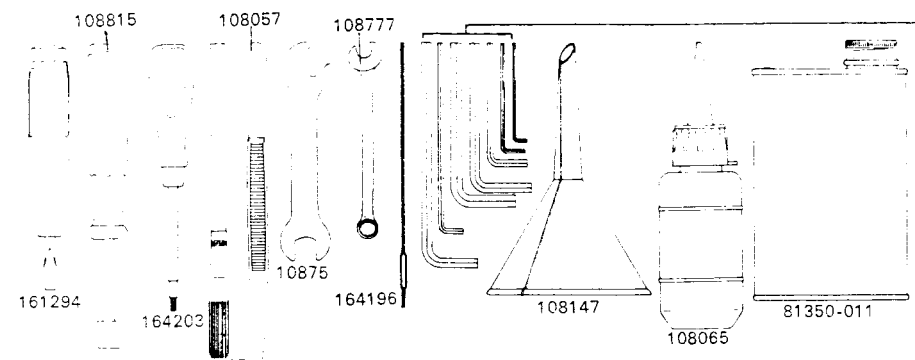

- WRENCH NUMBERS**
 1/16-81440
 5/64-820193-003
 1/8-820193-005
 5/32-108452
 3/16-820193-007
 3/32-820193-009
 7/32-820193-010
 1/16-820193-002

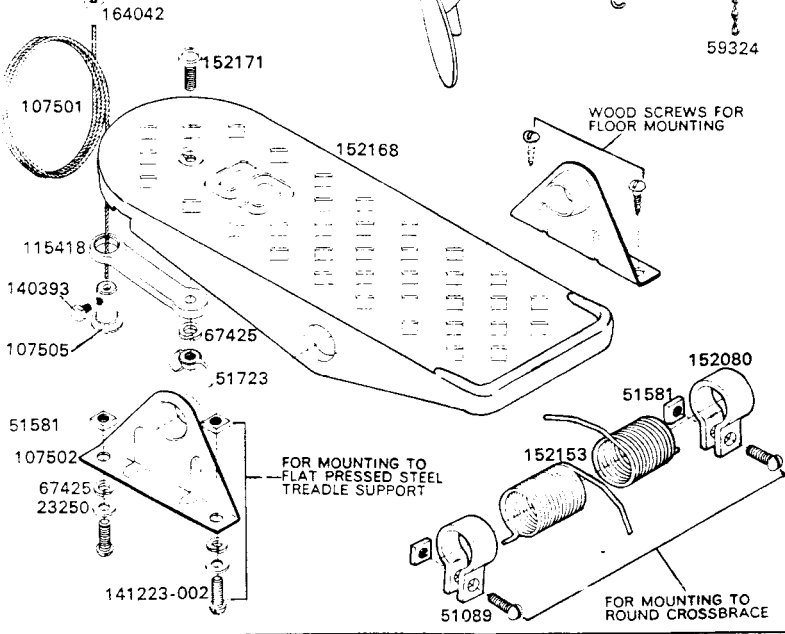
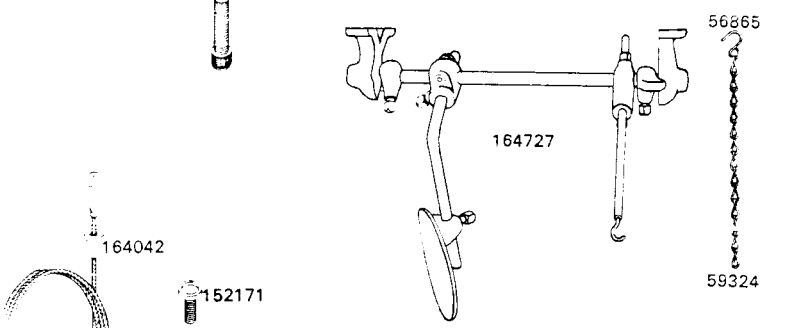
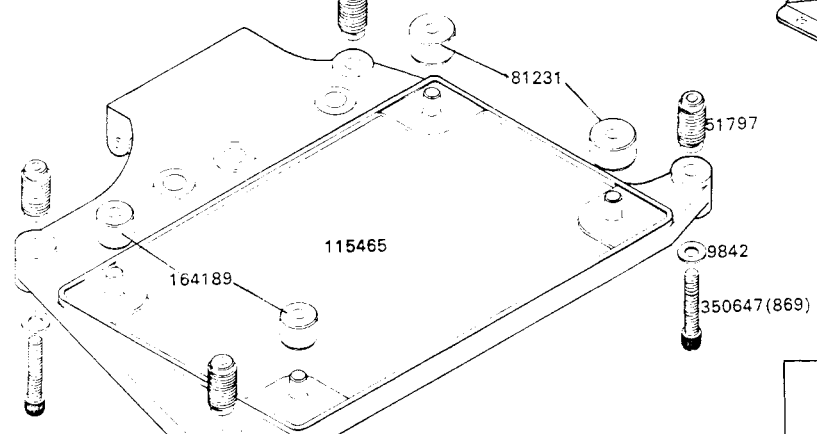
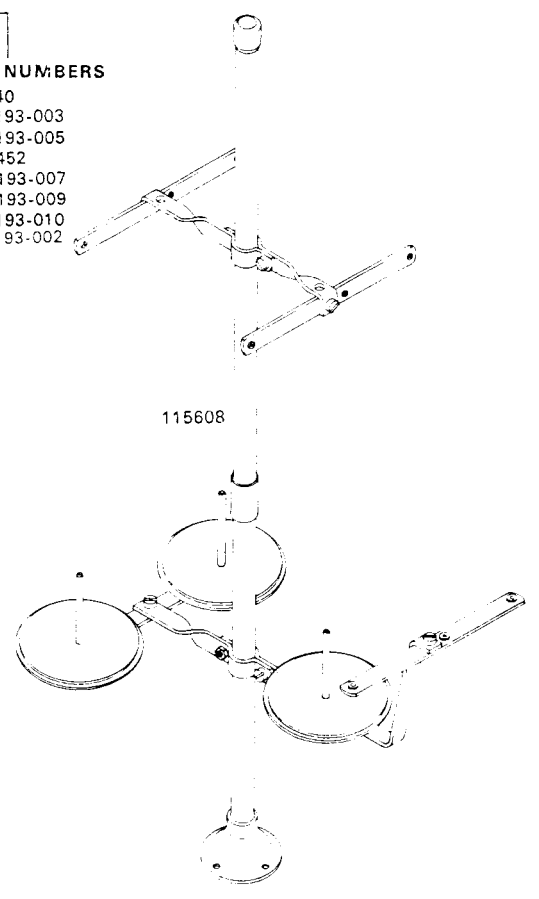
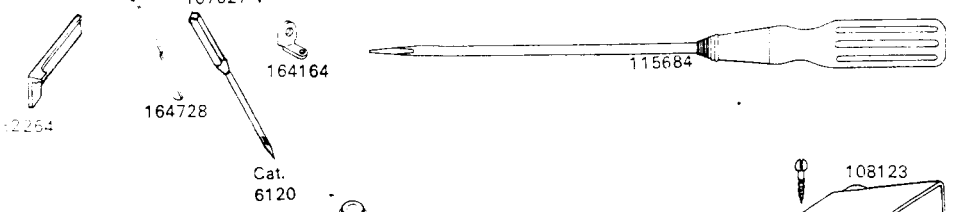

Available at an Extra Charge

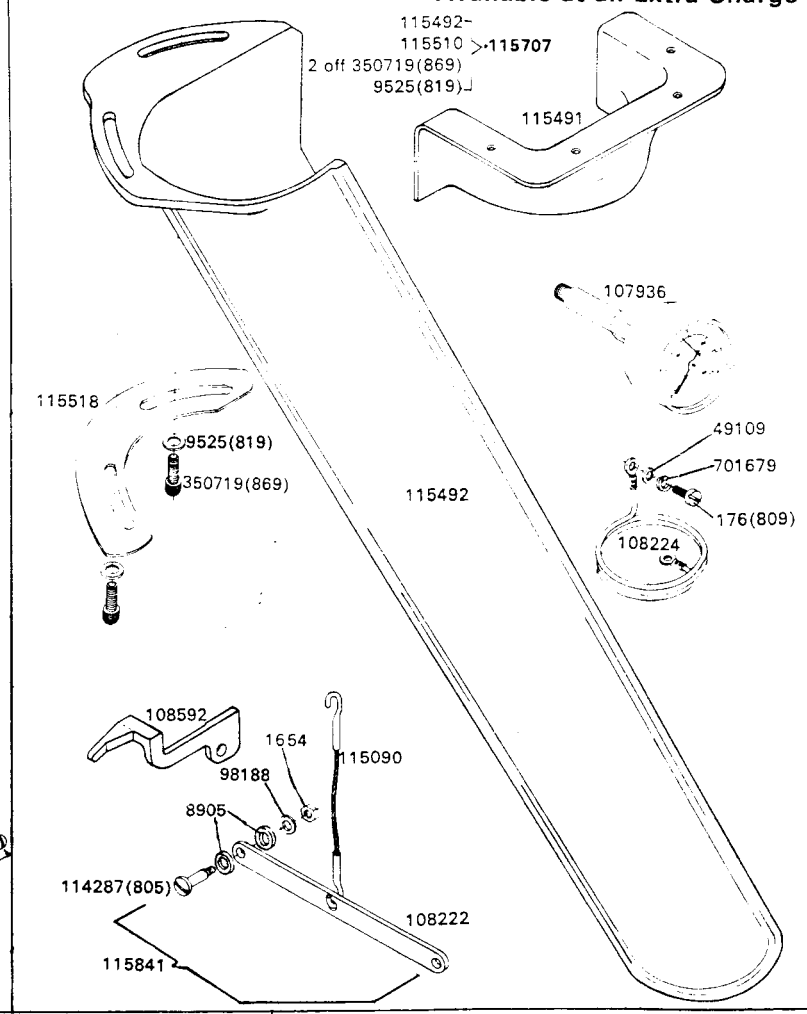

K

L

M

PARTS CHART FOR

SINGER

992_{E5} 992_{E11}

MACHINES

ON-OFF LIST OF PARTS FOR 992E11 MACHINE

This is the same as 992E5 machine with the following exceptions:-

Part On	Description	Part Off
115990	Chip Guard	115417
115562	Cloth Plate	115515
115847	Cloth Plate complete Nos. 1700(819), 114246(809), 115562, 115555 and two 237(809)	115586
164615	Feed (back) Dog Section (left)	164367
164616	Feed (back) Dog Section (right)	164280
164617	Feed (back) Dog complete Nos. 1100(830), 164615 and 164616	115339
115189	Feed (front) Dog	115162
115992	Knife (stationary) and Needle Guard Holder	115140
115993	Knife (stationary) and Needle Guard Holder (adjustable) complete	115141
115993	Knife (stationary) and Needle Guard Holder (adjustable) with Gib complete	115142
115625	Machine Frame Oil Splash Guard (top)	108975
115697	Machine Frame Top Cover with 108300 and two 108253 (for agents only)	115695
115696	Machine Frame Top Cover Assembly Nos. 39541, 1607(809), 107085(429), 107085(431), 107085(624), 107086(430), 108300, 108864, 115484, 115545, two each 1628(809), 98188, 108253, four each 1698(809), 115541 and 931084	115694
115986	Needle Guard (right)	—
115995	Needle Guard (left)	115144
115988	Needle Guard Holder..	—
115171	Needle Holder Driving Lever with 108479, 108278 and two each 108275, 113195 and 114166	108277
115414	Needle Holder Thread Guide	115118
164626	Presser Foot Body	164378
164146	Presser Foot Chaining Off Finger	164379
164627	Presser Foot complete Nos. 50169(809), 50225(809), 164146, 164147, 164360 and 164626	164380
115170	Needle Holder with 113195 and 114259-451 (for agents only)	—
107085(624)	Tension (heavy) complete (blue) Nos. 107084, 107178, 107625, 113180(624), 113191(888), 114117(803) and two 2102	—
113180(624)	Tension (heavy) Regulating Thumb Nut (blue)	—
115688	Thread (looper) Plate Cover with 109927(869)	115772
115689	Thread (looper) Plate Cover 115688 with 107095, 107096, 107097 and 1094(819)	115773
101949	Throat Plate	81425-003
117001	Thread Unwinder (four spools) complete.	115608

TO PROVIDE FST 512 WITH A 2mm NEEDLE SPACING

115337	Needle Holder with 82322, 115338, 853(830) and two 350683(869)	
115942	Needle Holder Driving Lever with 115337, 108479, two each 108275, 113195 and 114259	
115338	Needle Holder Stop Pin (adjustable)	
115159	Presser Foot Body	
115395	Presser Foot Chaining Off Finger	
115396	Presser Foot Tape Guide Plate	
51362(809)	Presser Foot Tape Guide Plate Screw	
164147	Presser Foot Clamping Plate	
50225(809)	Presser Foot Clamping Plate Screw	
164380	Presser Foot Guide	
50169(809)	Presser Foot Guide Screw	
115160	Presser Foot complete Nos. 50225(809), 50169(809), 164360, 164147, 115159, 115395, 115396 and two 51362(809)	
115161	Throat Plate	
115413	Needle Guard (front)..	—

ON-OFF LIST OF PARTS FOR CHAIN CUTTER RETRO-FIT KIT 117029 (FOR 992E11)

This is the same as the 117028 with the following exceptions:-

(117029)		(117028)
115174	Chain Cutter Knife Holder and Feed Bar Guide	108386
115733	Cloth Plate	115727
115734	Cloth Plate with 1700(809), 114246(809), 115555 and two 237(809)	115728
115630	Machine Frame Oil Splash Guard (top)	115494

PART No.	DESCRIPTION	LOCATION
10875	Wrench (flat)	K5
17022	Thread (looper right hand) Take-up Screw Washer	H7
20822	Looper (right hand) Carrier Connecting Link Adjusting Sleeve Wick Clip	E8
21079	Needle Post Oil Wick Sleeve Retaining Clamp	D3
23250	Treadle Hinge Bracket Bolt Washer	L8
39541	Cloth Plate Hinge Stud Washer	A8
42438	Presser Bar (swing-out) Opening Lever Hinge Screw Washer	D3
49109	Earthing Wire Washer	M7
50073(809)	Machine Frame Top Cover Screw (2)	F2
50169(809)	Presser Foot Guide Screw	—
50225(809)	Presser Foot Clamping Plate Screw	—
50225(809)	Needle Guard Screw	C7
50318(818)	Thread (looper) Plate Thread Bushing Screw	H7
50364(832)	Presser Bar Lifting Lever Stop Screw	B2, B3
50808	Machine Frame Oil Plug Bracket Set Screw Access Plug	—
50811(803)	Knife (stationary) and Needle Guard Holder Position Screw	C7
51082-002	Treadle Hinge Bracket Bolt 141223-002 with 51581	—
51089	Treadle Position Collar Bolt	L8
51224(818)	Chain Cutter Knife Holder and Feed Bar Guide Cover Securing Screw	L2
51362(830)	Needle Holder Thread Guide Screw	D5
51369(819)	Feed Eccentric Cover Hinge Bracket Screw (2)	A8
51369(803)	Knife (movable) Lever Hinge Stud Set Screw (2)	B6
51369(809)	Presser Bar Lifting Lever Stop Plate Screw (3)	B2
51423(850)	Presser Bar Lifting Lever (long) Hinge Stud	A3
51581	Treadle Position Collar Bolt Nut	K8
51720(819)	Presser Bar Lifting Lever Hinge Stud Nut	B3
51723	Treadle Extension Wing Nut	K8
51797	Machine Base Mounting Screw Insert (4)	L6
56865	Chain Hook (small)	L7
59324	Chain (8 in long) with 56865	L7
59456	Looper (left hand) Carrier Washer	G6
67425	Treadle Extension Wing Nut Lock Washer	K8
81202(813)	Feed Eccentric Oil Cover	A7
81231	Machine Cushion (large)	K8
81350-011	Tin of Oil (500 ml, Type H)	L5
81425-003	Throat Plate	C5
81433	Throat Plate Guide with 853(830)	C7
81440	Wrench (short) for 1/16 in Socket Head Screw	L5
81816	Machine Frame Top Bracket Plug	—
82264	Knife (movable)	D6, K5
82322	Needle Stop Pin	D5
86989	Machine Frame Top Bracket Set Screw Access Hole Plug (rubber)	—
87029	Knife (movable) Lever Bearing and Attachment Bracket	C5
87262	Knife (movable) Lever Bearing and Attachment Bracket with 1259(803)	C5
90100	Oil Pipe Retaining Clip	E6, F4
98188	Tension Thread Guide Securing Nut Washer	E2
98188	Presser Bar Lifter Operating Arm Bracket Bolt Washer	M8
98930	Machine Frame Rotary Shaft Ball Sleeve Guide	—
101832	Feed Lifting Eccentric	B7
101896	Thread (looper right hand) Tube (lower)	H6
101970	Looper (right hand) Position Collar	F6
108132	Knife (movable) Holder	D6
108401	Oil Reservoir Oil Sight Gauge Seal (O-Ring)	E8
108430	Belt Cover	H1
108442	Feed (back) Bar Connection	B7
108445-010	Feed (front) Eccentric (108445-006 to 108445-036 available to order)	A7, B7
108445-010	Feed (back) Eccentric (108445-006 to 108445-036 available to order)	A7, B7
108447	Feed (front) Bar Connection	B7
108450	Feed Eccentric Cover Hinge Bracket	A8
108461	Machine Frame Top Bracket Cover Latch Spring	E3
108462	Machine Frame Top Bracket Cover Latch Spring Pin	E3
108464	Knife (movable) Lever Guide	C5
108471	Knife (stationary) and Needle Guard Holder Sleeve Stud	D7
108472	Knife (stationary) and Needle Guard Holder Sleeve	D6
108476	Looper (left hand) Driving Shaft Access Hole Plug	—
108476	Looper (right hand) Driving Shaft Access Hole Plug	—
108477	Looper (left hand) Driving Shaft Bushing (back)	C4
108477	Looper (right hand) Driving Shaft Bushing (back)	D4
108478	Looper (left hand) Driving Shaft Bushing (front)	E5
108486	Looper (right hand) Carrier Connecting Link Adjusting Sleeve Wick	E6
108492	Looper (right hand) Driving Shaft Bushing (front)	E5
108494	Looper (right hand) Driving Shaft Oil Wick	F6
108496	Looper (right hand) Four-bar Linkage Mechanism Stabiliser	F5
108497	Looper (right hand) Four-bar Linkage Mechanism Stabiliser 108496 with 108498 and two 350680	F5
108498	Looper (right hand) Four-bar Linkage Mechanism Stabiliser Support Bracket	F5
108500	Machine Frame Bracket Assembly with 107024 and 187(805)	—
107024	Machine Frame Bracket Key	—
107025	Machine Frame Closing Plate	E6

PART No.	DESCRIPTIO	LOCATION
107027	Machine Frame Hole Plug	—
107028	Machine Frame Oil Plug Bracket	C7
107029	Machine Frame Oil Pressure Gauge Connection Plug	G5
107033	Machine Frame Rotary Shaft Ball Bearing Housing	J3
107034	Machine Frame Rotary Shaft Ball Bearing Housing Gasket	J3
107037	Machine Frame Rotary Shaft Oil Metering Pin	—
107038	Machine Frame Rotary Shaft Plug	D5
107045	Machine Pulley with two 448(830)	H2
107046	Machine Pulley Cap	J1
107055	Needle Driving Shaft Crank Connection Roller (27)	—
107065	Oil Pump Drive Pin	F5
107066	Oil Pump Rotor (inner)	G4
107067	Oil Pump Rotor (outer)	G4
107071	Oil Reservoir Oil Sight Gauge	F8
107075	Oil Pump Relief Valve	F4
107077	Oil Pump Relief Valve Plunger	F4
107078	Oil Pump Relief Valve Spring	F4
107081	Presser Bar (swing-out) Opening Lever	D3
107084	Tension (heavy) Spring	F1
107085(429)	Tension (heavy) complete (green) Nos. 107178, 107625, 107084, 113180(431), 113191(888), 114117(803) and two 2102	F1
107085(431)	Tension (heavy) complete (red) Nos. 107178, 107625, 107084, 113180(429), 113191(888), 114117(803) and two 2102	F1
107088(430)	Tension (light) complete (yellow) Nos. 107178, 107625, 164157, 113180(430), 113191(888), 114117(803) and two 2102	F1
107091	Thread (looper) Plate with 462(830)	H7
107092	Thread (looper) Plate complete Nos. 1423(809), 1443(809), 1607(809), 50318(818), 107091, 101896, 164163, 164165, 164173 and 164449	J6
107095	Thread (looper) Plate Cover Hinge Bracket	J8
107096	Thread (looper) Plate Cover Hinge Pin	H8
107097	Thread (looper) Plate Cover Latch Spring	J7
107115	Feed Bar Guide	A7
107158	Machine Frame Oil Pressure Gauge Connection Plug Gasket	G5
107160	Feed (back) Bar Connection Bearing	B7
107162	Feed Bar Hinge Pin (eccentric)	A7
107169	Oil Return Filter (front) complete with 115897, 165157 and two 107898	E7
107172	Feed Eccentric Cover Latch Spring	B8
107177	Machine Frame Rotary Shaft Ball Bearing Retaining Ring	J3
107178	Tension (heavy) Spring Bushing	F1
107178	Tension (light) Spring Bushing	E1
107188	Knife (movable) Lever Hinge Pin	C6
107191	Knife (movable) Lifting Lever Retaining Washer	C6
107192	Knife (movable) Lifting Lever Retaining Washer and Oil Sling	C6
107204	Oil Reservoir Drain Plug	E7
107501	Foot Lifter Operating Cable	K7
107502	Treadle Hinge Bracket	L8
107505	Foot Lifter Operating Cable Retaining Collar with 140393	K8
107512	Treadle Hinge Bracket 107502 with two each 23250, 51082-002 and 67425	—
107513	Foot Lifter Operating Cable complete Nos. 107501 and 107505	—
107546	Treadle 115420 with two 107502, four each 23250 and 67425	—
107575	Knife (movable) Lever with two 141292(889)	C6
107625	Tension (heavy) Spring Cover	F1
107625	Tension (light) Spring Cover	E1
107626	Treadle 115420 with two 107502 and four wood screws 3/4 in No. 12 R. H.	—
107627	Lint Cleaning Brush	K5
107629	Feed (back) and (front) Bars complete Nos. 106442, 106447, 107160, 164006, 164018, 164687, 165134, two each 1718(803), 9525, 164604 and 164009	B7
107828	Feeler Gauge (0.04 in (1mm))	L6
107898	Oil Return Filter (front) Screen (upper)	E7
107898	Oil Return Filter (front) Screen (lower)	E7
107936	Oil Pressure Gauge	M7
108026	Machine Frame Rotary Shaft Bushing (front)	C6
108057	Tweezers	K5
108065	Oil Dispenser	L5
108117	Machine Frame Rotary Shaft Plug Sleeve	D5
108123	Belt Cover (rear)	L6
108147	Oil Funnel	L5
108158	Oil Deflector	E6
108222	Presser Bar Lifter Operating Arm	M8
108224	Earthing Wire	M8
108248	Knife (movable) Lever Spacer	—
108249	Knife (movable) Lever Hinge Stud	B6
108251	Looper (left hand)	G6
108253	Looper (right hand) Thread Tube (upper)	E2
108253	Looper (left hand) Thread Tube (upper)	F2
108261	Machine Frame (top) Bracket Cover (hinged)	E3
108262	Machine Frame (top) Bracket Cover (hinged) 108261 with 227(819), 106461, 108263, 228661 and three 665(821)	E3
108263	Machine Frame (top) Bracket Cover Hinge	D2
108269	Needle Driving Shaft Crank	E4

PART No.	DESCRIPTION	LOCATION
108271	Needle Driving Shaft Crank Connection with 107055 (for agents only)	E4
108274	Needle Holder with 113195 (for agents only)	D6
108275	Needle Holder Driving Link (2)	D6
108277	Needle Holder Driving Lever with 108479 and two each 108275, 113195 and 114259-451	—
108279	Needle Holder Driving Lever with 113195 and 114259-451 (for agents only)	D6
108281	Needle Post Oil Wick (long)	D4
108282	Needle Post Oil Wick Connector	C3, D4
108283	Needle Post Oil Wick Holder	C3
108284	Needle Post Oil Wick Sleeve	D4
108286	Needle Post Washer	C3
108288	Presser Bar Housing with 42436, 107081, 114082(853), 114159(805), 114170, 164143(850) and 164416	D2
108289	Presser Bar Lifting Lever (short)	C3
108290	Needle Post Oil Wick (short)	D3
108291	Presser Bar Lifting Lever Shaft	B3
108292	Presser Bar Lifting Lever Shaft Bushing	C3
108293	Presser Bar Lifting Lever (short) Collar with 114091(869)	C3
108295	Presser Bar Lifting Lever Stop Plate	B2
108296(850)	Presser Bar (swing-out)	B4
108298	Thread Eyelet (needle thread)	E4
108300	Machine Frame Top Cover Plug	F2
108385	Chain Cutter Knife Holder and Feed Bar Guide Cover	L2
108386	Chain Cutter Knife Holder and Feed Bar Guide	L2
108389	Chain Cutter Knife (movable) Driving Fork with two 109927(869)	M1
108390	Chain Cutter Knife (movable) Driving Slide Block	M1
108391	Chain Cutter Knife (movable) Driving Slide Block Stud	M1
108394	Chain Cutter Knife (movable) Spring	M2
108399	Knife (movable) Lifting Lever	C6
108406	Chain Cutter Suction Pipe (available at an extra charge)	L4
108441	Chain Cutter Knives Oil Wick	M1
108445	Oil Pump Cover Oil Seal	M3
108451	Wrench (plastic handle) for 5/64 in Socket Screw	K5
108452	Wrench (long) for 5/32 in Socket Head Screw	L5
108479	Thread (needle) Controller	E5
108495	Chain Cutter Knife (movable) Driving Slide Block Stud Wick	M1
108531	Thread Eyelet (needle thread) Bridge	D4
108532	Needle Driving Shaft Position Collar with 114164(869)	E4
108585	Chain Cutter Suction Pipe Clip (available at an extra charge)	L3
108592	Looper (left hand) Setting Gauge	L8
108597	Chain Cutter Knife (movable) Driving Fork 108389 with 108390 and 108391	M2
108656	Oil Pump Body Clamping Screw Hole Plug Screw Gasket	G5
108667	Presser Bar Lifting Lever (long) assembly	B3
108669	Presser Bar Lifting Lever (long) Connection Rod	A3
108670	Presser Bar Lifting Lever (long) Connection Rod Cutter Pin (2)	B2, B3
108671	Presser Bar Lifting Lever (long) Tension Spring	B3
108673	Needle Driving Shaft Bushing (front) Thrust Washer	E4
108777	Combination Wrench	K5
108812	Thread (looper) Take-up	G7
108815	Wrench (socket)	K5
108864	Thread (needle) Guide Post Securing Nut Washer	E2
108882	Needle Driving Shaft (replacement) assembly (for agents only)	E3
108916	Machine Frame Rotary Shaft complete	F5
108917	Looper (left hand) Driving Shaft	F8
108919	Looper (right hand) Driving Shaft with 108494	F8
108975	Machine Frame Oil Splash Guard (top)	B5
109329(803)	Machine Frame Rotary Shaft Ball Bearing Housing Screw (4)	J3
109795(803)	Looper (right hand) Carrier Connecting Link Adjusting Screw (front)	F8
109927(869)	Looper (right hand) Carrier Connecting Link Hinge Pin Set Screw (2)	F8
109927(869)	Thread (looper) Plate Cover Hinge Pin Locking Screw	J8
109927(869)	Chain Cutter Knife (movable) Driving Fork Set Screw (2)	M1
109927(869)	Chain Cutter Knife (movable) Driving Slide Block Stud Set Screw	C8
113176	Knife (stationary) and Needle Guard Holder Sleeve Stud Lock Nut	D6
113176(819)	Machine Frame Top Bracket Cover Spring Pin Lock Nut	E3
113177	Machine Frame Rotary Shaft Nut	A7
113179	Oil Pump Relief Valve Spring Screw Stud Locking Nut	F3
113180(429)	Tension (heavy) Regulating Thumb Nut (green)	F1
113180(431)	Tension (heavy) Regulating Thumb Nut (red)	E1
113180(430)	Tension (light) Regulating Thumb Nut (yellow)	E1
113191(888)	Tension (heavy) Regulating Thumb Nut Lock Nut	E1 F1
113191(888)	Tension (light) Regulating Thumb Nut Lock Nut	E1
113195	Needle Holder Driving Link Hinge Screw Nut	E5
113195	Needle Holder Driving Lever Hinge Screw Nut	E5
113324	Needle Post Lock Nut	C3
114032(832)	Knife (stationary) Clamping Gib Screw	D6
114038	Looper (right hand) Four-bar Linkage Mechanism Stabiliser Securing Screw	F5
114038(809)	Oil Pump Body Clamping Screw Hole Plug Screw	G5
114071(819)	Feed Eccentric Cover Hinge Screw	A7
114077	Machine Frame Rotary Shaft Screw Stud	H2

PART No.	DESCRIPTION	LOCATION
114081	Oil Pump Relief Valve Spring Screw Stud	F4
114082	Presser Bar (swing-out) Opening Lever Hinge Screw	D3
114091(869)	Presser Bar Lifting Lever (short) Collar Set Screw	C3
114092(803)	Looper (left hand) Driving Shaft Crank Clamping Screw	—
114092(803)	Looper (right hand) Driving Shaft Crank Clamping Screw	—
114117(803)	Tension (heavy) Screw Stud	E2 F2
114117(803)	Tension (light) Screw Stud	E2
114130	Knife (stationary) and Needle Guard Holder Sleeve Stud Set Screw	D7
114142(809)	Belt Cover Screw (2)	H1, J2
114159	Pressure Regulating Thumb Screw Lock Screw	D2
114161(869)	Presser Bar Housing Screw (3)	C2
114164(869)	Needle Driving Shaft Position Collar Screw	E4
114170	Pressure Regulating Thumb Screw	D1
114188(869)	Needle Holder Driving Lever Locating Screw	D5
114222(869)	Needle Driving Shaft Crank Clamping Screw (2)	E3
114224(869)	Cloth Plate Position Collar Set Screw (2)	A6
114224(869)	Looper (left hand) Set Screw (2)	G8
114224(869)	Oil Pump Suction Filter Collar Securing Screw	F8
114224(869)	Presser Bar Lifting Lever Shaft Collar Set Screw (2)	C3
114246(809)	Cloth Plate Position Bracket Screw	B6
114246(809)	Feed Eccentric Cover Positioning Screw (for 117028)	L3
114256-451	Looper (left hand) Carrier Holder Clamping Screw	G7
114256-451	Looper (right hand) Driving Lever Clamping Screw	F5
114258-451	Looper (left hand) Driving Shaft Crank Connection Cap (upper) Screw	—
114258-451	Looper (right hand) Driving Shaft Crank Connection Cap (upper) Screw	—
114259-451	Needle Holder Driving Link Hinge Screw	D5
114259-451	Needle Holder Driving Lever Hinge Screw	D5
114263-451	Looper (left hand) Driving Shaft Crank Connection Cap (lower) Screw	—
114263-451	Looper (right hand) Driving Shaft Crank Connection Cap (lower) Screw	—
114264-451	Needle Driving Shaft Crank Connection Cap (lower) Screw	—
114287(805)	Presser Bar Lifter Operating Arm Bracket Bolt	L8
114290(809)	Oil Pump Suction Pipe Securing Screw	G4
114292(869)	Machine Frame Hole Plug Screw	—
114292(869)	Needle Driving Shaft Crank Hinge Pin Set Screw	E4
115007	Machine Frame Rotary Shaft Key	D5
115061	Oil Pump Relief Valve Body	F4
115062	Oil Pump Relief Valve complete Nos. 107075, 107078, 107077, 114081, 115061 and 113179	F3
115067	Needle Driving Shaft Crank Hinge Pin Oil Wick	E4
115068	Gauge (accessories) Low Lift	M8
115090	Presser Bar Lifter Connecting Cable	M8
115111	Looper (right hand)	E6
115118	Needle Holder Thread Guide	D5
115140	Knife (stationary) and Needle Guard Holder	C7
115141	Knife (stationary) and Needle Guard Holder (adjustable) complete Nos. 141444(831), 164745 and 165062	D7
115142	Knife (stationary) and Needle Guard Holder (adjustable) with Gib complete Nos. 3146, 114032(832), 164744 and 165063	D7
115143	Oil Pipe Guide Pin	E5
115143	Thread (Looper) Plate Cover Latch Spring Pin	J7
115144	Needle Guard (front)	C7
115162	Feed (front) Dog	C6
115227	Chain Cutter Knife (movable) Shaft Drive Collar with three 141087(869)	M2
115228	Chain Cutter Knife (movable) with 115240	M2
115240	Chain Cutter Knife (movable) Drive Pin	M2
115331	Chain Cutter Knife (movable) Shaft	L1
115332	Chain Cutter Knife (stationary)	M1
115333	Chain Cutter Knife (stationary) Extension	M1
115339	Feed (back) Dog complete Nos. 1100(830), 164367 and 164280	B6
115390	Presser Bar Lifting Lever Hinge Stud	B3
115391	Looper (right hand) Setting Gauge	M8
115417	Chip Guard complete	G7
115418	Treadle Extension	K8
115420	Treadle 152168 with 51723, 115418, 152171 and 67425	—
115421	Treadle 115420 with 152153 and two 152080	—
115440	Looper (right hand) Carrier Connecting Link Eccentric Adjusting Sleeve Cap Plug	F6
115441	Looper (right hand) Four-bar Linkage Mechanism complete Nos. 1700(809), 109795(803), 115440, 164068, two each 1209(830) and 132584	F6
115465	Machine Base	K6
115466	Oil Reservoir	E7
115484	Tension Thread Guide	D1
115485	Machine Frame (top) Bracket Closing Plate Gasket	F4
115486	Machine Frame (top) Bracket Closing Plate with 115485	F3
115491	Chip Chute Sleeve	M7
115492	Chip Chute	M8
115494	Machine Frame Oil Splash Guard (top) (992E45)	L1
115501	Feed Eccentric Cover	B7
115510	Oil Reservoir Gasket	E7

PART No.	DESCRIPTION	LOCATION
115514	Oil Breather Plug Screw	F4
115515	Cloth Plate	A6
115517	Oil Filler Cap and Flow Indicator	F3
115518	Chip Chute Support Plate	L7
115519	Machine Frame Support Pin	E7
115534	Oil Pump Suction Pipe	G4
115536	Oil Pump Suction Filter Cap	F8
115538	Oil Pump Suction Pipe Gasket	G4
115540	Oil Filler Cap Oil Seal	F3
115541	Tension Regulator Thread Guide	E2
115545	Thread (needle) Guide Post	E2
115555	Cloth Plate Lock Spring	B6
115571	Cloth Plate Lock Spring Retaining Screw Stud	D8
115572	Oil Pipe	E4, E5
115586	Cloth Plate Nos. 1700(809), 114246(809), 115515, 115555 and two 237(809)	A5
115589	Oil Reservoir 115466 with 107071, 107204 and 106401	F7
115598	Machine Frame Handle	A8
115608	Thread Unwinder (three spools) complete	M5
115684	Screw Driver	L5
115694	Machine Frame Top Cover assembly Nos. 1607(809), 107085(429), 107085(431), 107086(430), 108300, 108864, 115484, 115545, 228661, two each 1828(809), 98188, 108253, three each 1698(809), 115541 and 931084	G3
115695	Machine Frame Top Cover complete with 108300, 228661 and two 108253 (for agents only)	E2
115707	Chip Chute complete Nos. 115492, 115510, two each 350719(869) and 9525(819)	M8
115727	Cloth Plate (for 117028)	L2
115728	Cloth Plate 115727 with 1700(819), 114246(809), 115555 and two 237(809) (for 117028)	M2
115729	Feed Eccentric Cover (for 117028)	K3
115739	Oil Pipe Banjo Connection (2)	F4, E6
115740	Oil Pipe Banjo Connection Washer (fibre) (4)	F4, E5,
115741	Oil Pipe Banjo Connection Retaining Screw	F4
115742	Oil Pipe Banjo Connection Retaining Screw (lower)	E6
115772	Thread (looper) Plate Cover with 109927(869)	J7
115773	Thread (looper) Plate Cover 115772 with 1094(819), 107095, 107096 and 107097	J7
115814	Oil Pipe 115572 with two 90100 and 115739	E6
115841	Presser Bar Lifter Operating Arm 108222 with 114287(805), 98188, 1654, 115090 and two 8905	—
115897	Oil Return Filter (front) Pad	E7
117028	Chain Cutter Retro-fit Kit complete (for 992E5)	K1
117029	Chain Cutter Retro-fit Kit complete (for 992E11)	—
125399	Cloth Plate Hinge Stud Friction Washer	A6
132584	Looper (right hand) Carrier Connecting Link Hinge Pin Oil Wick (2)	F6
139026	Machine Frame Rotary Shaft Ball Bearing	H3
140050(833)	Knife (movable) Clamp Screw	D6
140393(830)	Looper (left hand) Carrier Holder Set Screw (right)	G6
140393	Foot Lifter Operating Cable Retaining Collar Screw	K8
140409	Machine Frame Oil Plug Bracket Set Screw	—
140409(869)	Needle Holder Driving Lever Set Screw	D5
140416(853)	Machine Pulley Cap Screw	J1
140509(809)	Chip Guard Screw (upper)	H7
140596(830)	Looper (left hand) Carrier Holder Set Screw (left)	G7
140930(869)	Looper (left hand) Driving Shaft Crank Position Screw	E5
140930(869)	Looper (right hand) Driving Shaft Crank Position Screw	E5
141004(830)	Knife (stationary) and Needle Guard Holder Locking Screw	C7
141087(869)	Chain Cutter Knife (movable) Drive Pin Securing Screw	M2
141087(869)	Chain Cutter Knife (movable) Shaft Drive Collar Set Screw (2)	M2
141223-002	Treadle Hinge Bracket Bolt	L8
141292(869)	Knife (movable) Lever Hinge Pin Set Screw (2)	C5
141292(869)	Looper (left hand) Carrier Set Screw	G6
141292(869)	Needle Driving Shaft Crank Hinge Pin Set Screw	E4
141444(831)	Knife (stationary) and Needle Guard Holder Screw	C7
141575	Feed Eccentric Cover Positioning Screw	B7
152080	Treadle Position Collar with 51089	K8
152153	Treadle Spring	L8
152168	Treadle	K8
152171	Treadle Extension Swivel Stud	K7
161294	Screw Driver (plastic handle) (large)	K5
164004	Feed Bar Slide Block (back) (2)	B6
164006	Feed (front) Bar with 164010	B6
164009	Feed (back) Bar Connection Hinge Screw Stud	—
164009	Feed (front) Bar Connection Hinge Screw Stud	B6
164010	Feed (back) Bar Connection Hinge Screw Stud Position Pin	B7
164010	Feed (front) Bar Connection Hinge Screw Stud Position Pin	B6
164018	Feed (front) Bar Connection Bearing	A7
164027(819)	Knife (movable) Clamp	D6
164030	Knife (movable) Holder Screw Bearing	C8
164042	Foot Lifter Operating Cable Friction Sleeve	K7
164043	Knife (stationary) and Needle Guard Holder Spring	C7

PART No.	DESCRIPTION	LOCATION
164046	Looper (left hand) Carrier with 141292(869), 114224(809) and 164202	H5, G6
164053	Looper (left hand) Driving Shaft Crank Thrust Bearing	E5
164053	Looper (right hand) Driving Shaft Crank Thrust Bearing	E5
164068	Looper (right hand) Locking Screw Stud	F6
164091	Thread (looper right hand) Take-up with 164555	G7
164093	Machine Frame Rotary Shaft Ball Sleeve	—
164098	Machine Frame Rotary Shaft Oil Return and Ball Bearing Grease Retainer	H3
164100	Machine Frame Rotary Shaft Thrust Bearing	H3
164143(850)	Presser Bar (upright)	D3
164144	Presser Bar (upright) Spring (alternative to 164416)	—
164147	Presser Foot Clamping Plate	—
164157	Tension (light) Spring	E1
164163	Thread (looper right hand) Take-up Eyelet (adjustable)	H7
164164	Thread (looper right hand) Thread Eyelet (movable)	K5
164165	Thread (looper right hand) Thread Eyelet (stationary)	H7
164173	Thread (looper) Plate Thread Bushing	H7
164176	Thread (looper right hand) Take-up Plate	—
164189	Machine Cushion (small)	K6
164196	Threader (6)	K5
164202	Looper (left hand) Stop Pin	G6
164203	Feed Eccentric Extractor	K5
164280	Feed (back) Dog Section (right)	—
164360	Presser Foot Guide	—
164367	Feed (back) Dog Section (left)	—
164378	Presser Foot Body	—
164379	Presser Foot Chaining-off Finger	—
164380	Presser Foot complete Nos. 50169(809), 50225(809), 164147, 164360, 164378 and 164379	B4
164416	Presser Bar (upright) Spring (heavy)	D2
164449	Thread (looper right hand) Thread Eyelet (movable)	H7
164525	Knife (stationary) and Needle Guard Holder Spring Stud	D7
164555	Thread (looper right hand) Take-up Guide Wire	H7
164660	Looper (left hand) Carrier Holder with 114256-451, 140393(830) and 140596(830)	G6, H8
164661	Looper (left hand) Carrier Holder 164660 with 1324(803), 59456 and 164046	H6
164687	Feed (back) Bar with 164010	B7
164727	Knee Lifter complete	L7
164728	Knife (stationary)	K5, D8
164744	Knife (stationary) Clamping Gib	D6
164745	Knife (stationary) and Needle Guard Holder Body with two 50611(803)	C7
165055	Looper (left hand) Thread Tube (lower)	D7
165059(813)	Needle Guard Holder	C7
165134	Feed Bar Slide Block (front)	B7
165157	Oil Return Filter (front) Fastener	E7
165290	Cloth Plate Position Collar with two 114224(869)	A8
165290	Presser Bar Lifting Lever Shaft Collar with two 114224(869)	C3
165291	Knife (movable) Guard (lower)	D8
165370	Machine Frame Hole Plug	—
165373	Machine Frame Top Bracket Position Dowel Pin	—
165384	Machine Frame Oil Drain Plate Screen	D8
165395	Machine Frame Oil Drain Plate	D7
165406	Machine Frame Wearing Plate	E6
165487	Knife (movable) Guard (upper)	D8
165519	Machine Frame Oil Drain Plate Filter (felt)	D7
175032(819)	Feed Bar Guide Screw Washer (2)	A7
175032(819)	Thread (looper) Plate Cover Hinge Bracket Screw Washer (2)	J8
228661	Thread (looper) Plate Cover Stop (rubber) (2)	H8
228661	Machine Frame Top Bracket Cover Stop (rubber)	E2
228661	Machine Frame Top Cover Tension Screw Hole Plug	F2
271779	Cloth Plate Lock Spring Retaining Screw Stud Sleeve	D8
350647(869)	Oil Pump Body Clamping Screw	G4
350647(869)	Machine Base Mounting Screw (4)	L6
350683(869)	Needle Clamping Screw	D5
350687(869)	Machine Frame Top Bracket Set Screw	—
350680	Looper (right hand) Four-bar Linkage Mechanism Stabiliser Screw	F5
350719(869)	Oil Pump Cover Screw (3)	H3
350719	Chip Chute Support Plate Screw	L7
350744(869)	Machine Frame Bracket Screw	—
350744	Oil Reservoir Screw (6)	D8, F8
701679	Earthing Wire Screw Washer	M8
820193-002	Wrench (regular) for 1/16 in Socket Head Screw	L5
820193-003	Wrench (regular) for 5/64 in Socket Head Screw	L5
820193-005	Wrench (regular) for 1/8 in Socket Head Screw	L5
820193-007	Wrench (regular) for 3/16 in Socket Head Screw	L5
820193-009	Wrench (long) for 3/32 in Socket Head Screw	L5
820193-010	Wrench (regular) for 7/32 in Socket Head Screw (2)	L5
931084	Tension (heavy) Screw Stud Washer	—
931084	Tension (light) Screw Stud Washer	E2
931286	Needle Post Lock Nut Washer	—
Cat. 6120	Needle Size 12	D6