

SINGER
312 T141

SINGER

INDUSTRIAL SEWING MACHINE

312

T 141

312T141 MACHINE

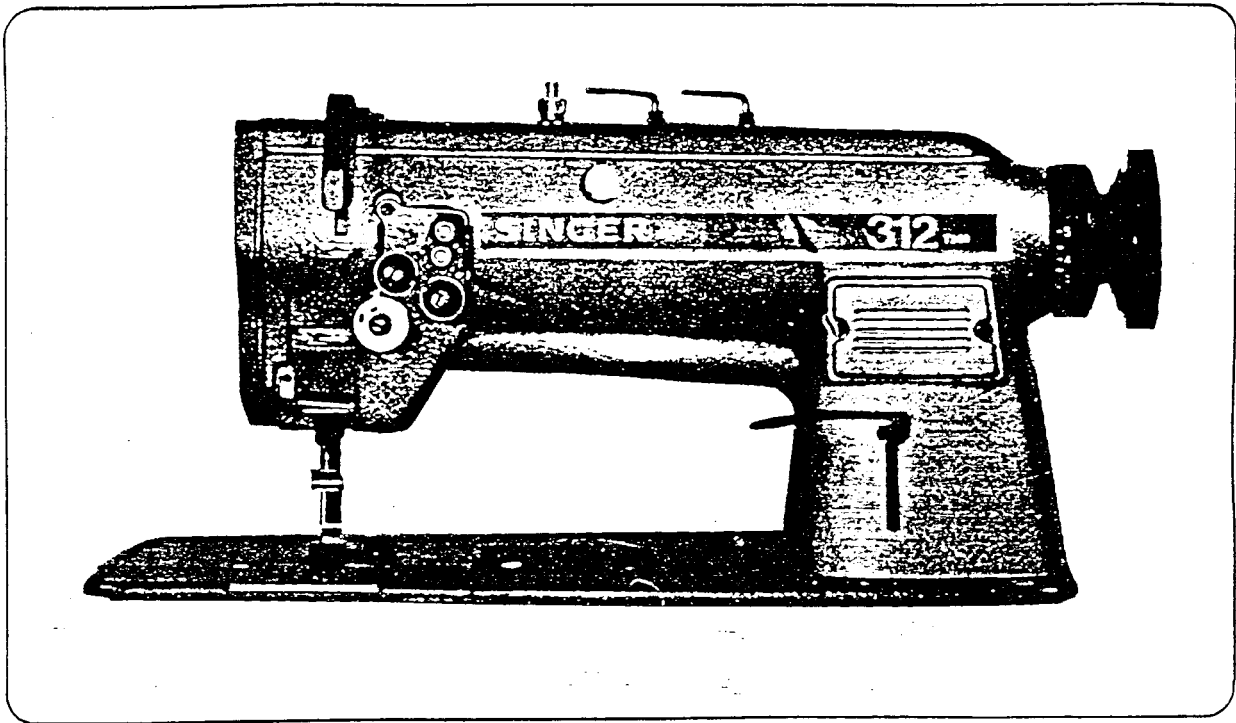

ILLUSTRATED PARTS LIST

1. TOTAL ASSY,

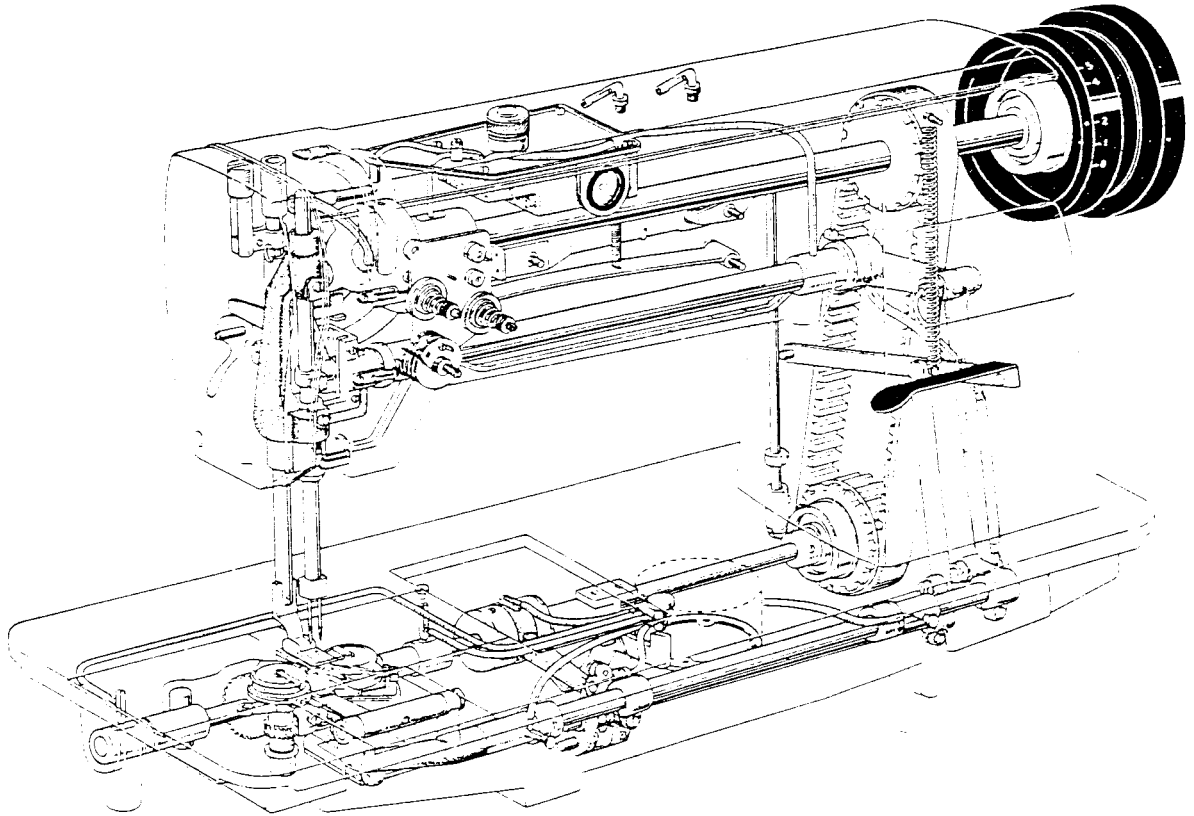

INDEX

	Page
1. Total assy	1
2. Arm and bed	2
3. Upper shaft mechanism	4
4. Presser foot mechanism	5
5. Thread take-up mechanism	6
6. Lower shaft mechanism	7
7. Lower feed mechanism	8
8. Hook mechanism	9
9. Lubrication mechanism	10
10. Reverse lever mechanism	12
11. Accessories (Accessories box)	13

2. ARM AND BED

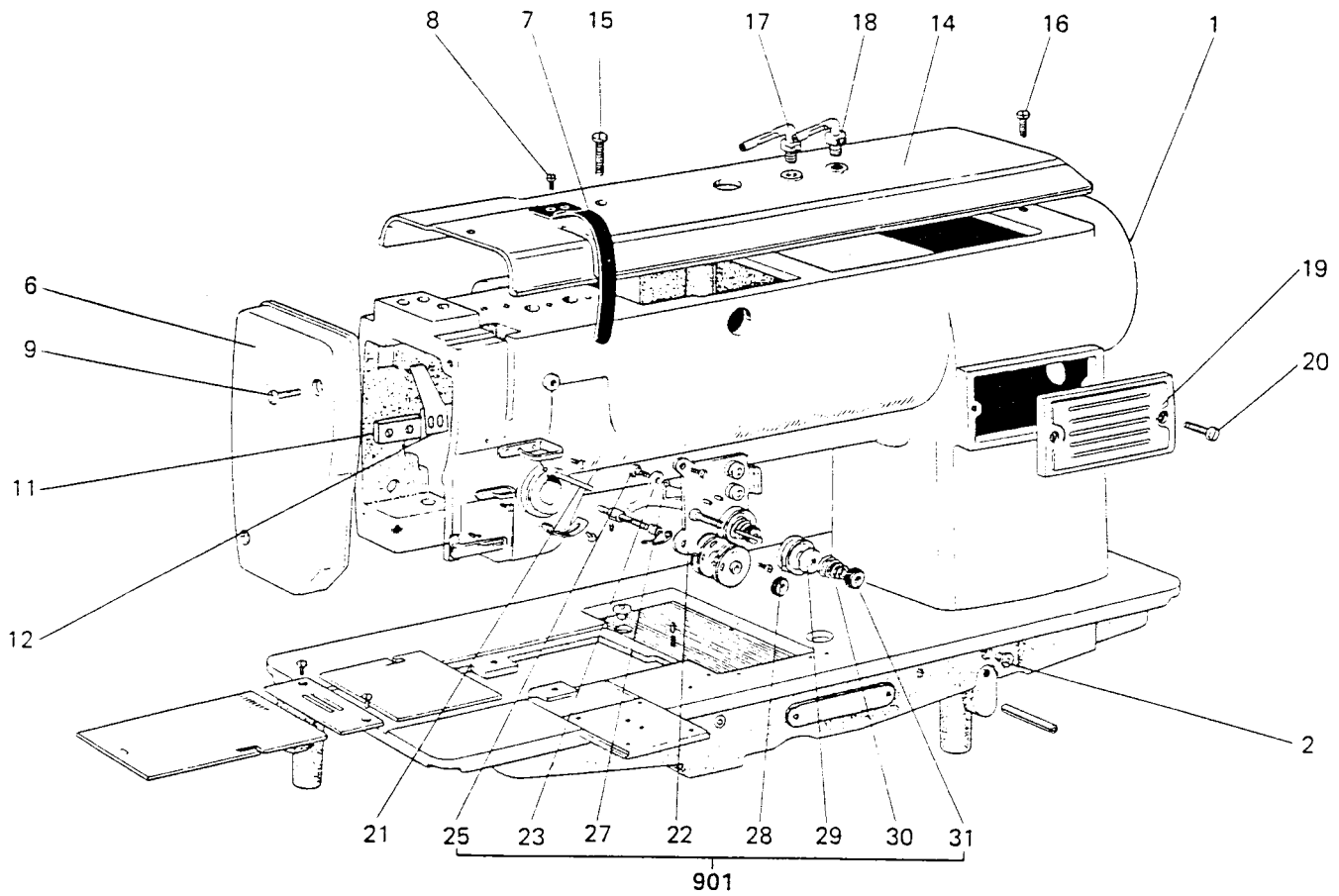

Ref. No.	Part No.	Description	Ref. No.	Part No.	Description
1	A610-E001	Arm and bed	27	A610-G027	Reverse spring
2	A610-G002	Cover (3)	28	A610-G028	Tension disc (4)
6	A610-G006	Face plate	29	A610-G029	Disc presser (2)
7	A610-G007	Thread take-up lever guard	30	A610-G030	Tension spring #3 (2)
8	A610-G008	Screw	31	A610-G031	Tension nut (3)
9	A610-S086	Face plate set screw (2)	901	A610-G901	Thread tension regulator Assy.
11	A610-G011	Washer			
12	A610-G012	Oil rejector			
14	A610-G014	Top cover			
15	A610-G015	Screw for top cover			
16	A610-S080	Screw for top cover			
17	A610-G017	Thread guide for top cover (2)			
18	A610-N007	Thread guide nut (2)			
19	A610-G019	Front cover			
20	A610-S091	Front cover screw (2)			
21	A610-G021	Thread releasing pin (large)			
22	A610-G022	Thread regulator plate			
23	A610-G023	Thread regulator plate (2)			
25	A610-S072	Screw (2)			

2. ARM AND BED

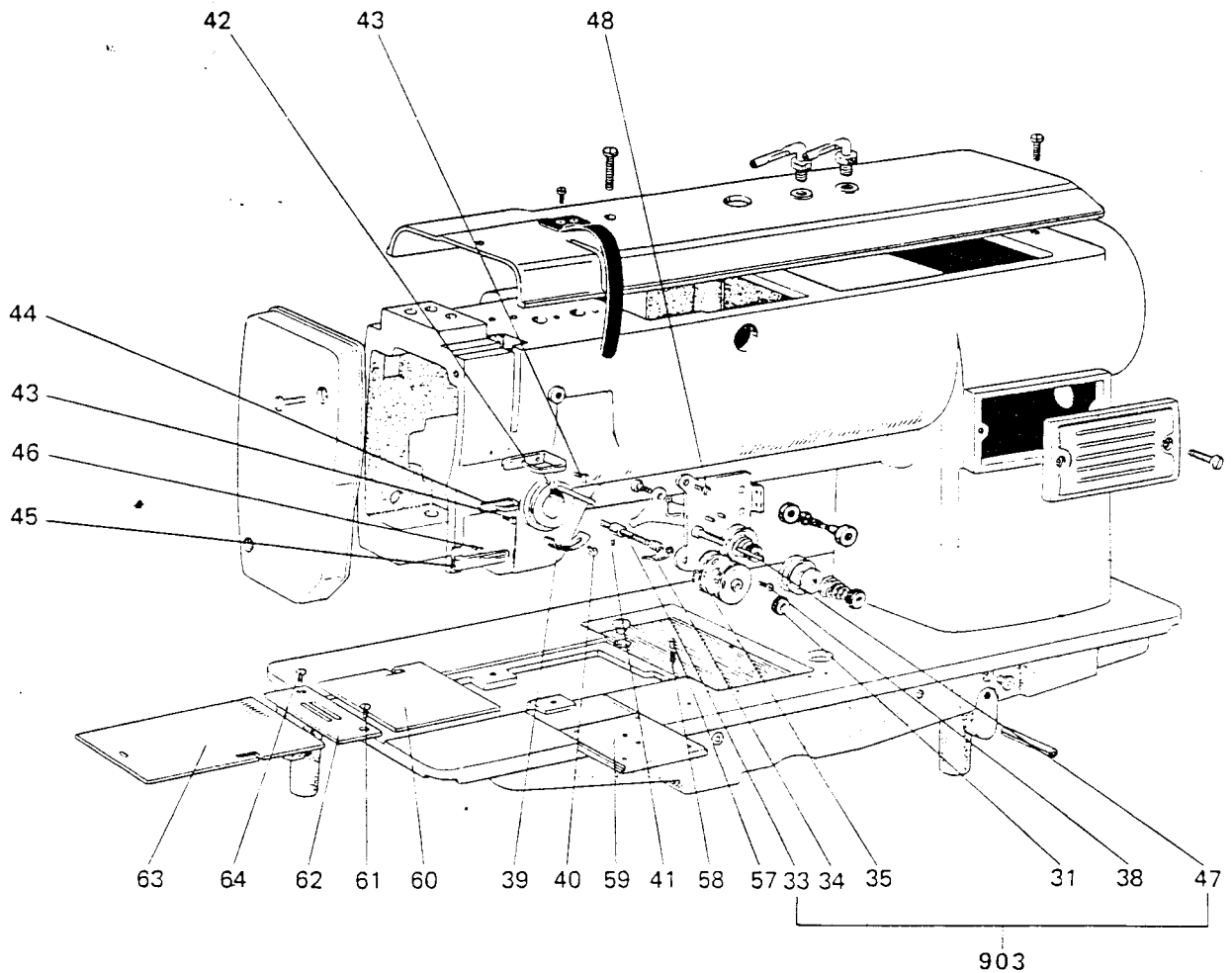

Ref. No.	Part No.	Description
33	A610-G033	Tension stud
34	A610-G034	Take-up spring
35	A610-G035	Thread controller disc Assy (2)
38	A610-S120	Screw
903	A610-G901	Thread tension regulator Assy.
39	A610-G039	Tension spring stopper
40	A610-S072	Screw
41	A610-G041	Screw (2)
42	A610-G042	Thread guide (upper)
43	A610-S074	Screw (2)
44	A610-G044	Thread guide (center)
45	A610-G045	Thread guide (lower)
46	A610-S074	Screw
47	A610-G047	Thread releasing pin (small) (2)
48	A610-S089	Screw
908		Thread guide disc Assy. (2)
57	A610-G057	Pin
58	A610-G058	Spring
59	A610-G059	Slide plate (front)
60	A610-G060	Slide plate (right)

Ref. No.	Part No.	Description
61	A610-S090	Screw
62	A610-GL14	Throat plate (Needle gauge 3/16)
	A610-GL19	Throat plate (Needle gauge 1/4)
63	A610-G063	Slide plate (left)
64	A610-S119	Screw

3. UPPER SHAFT MECHANISM

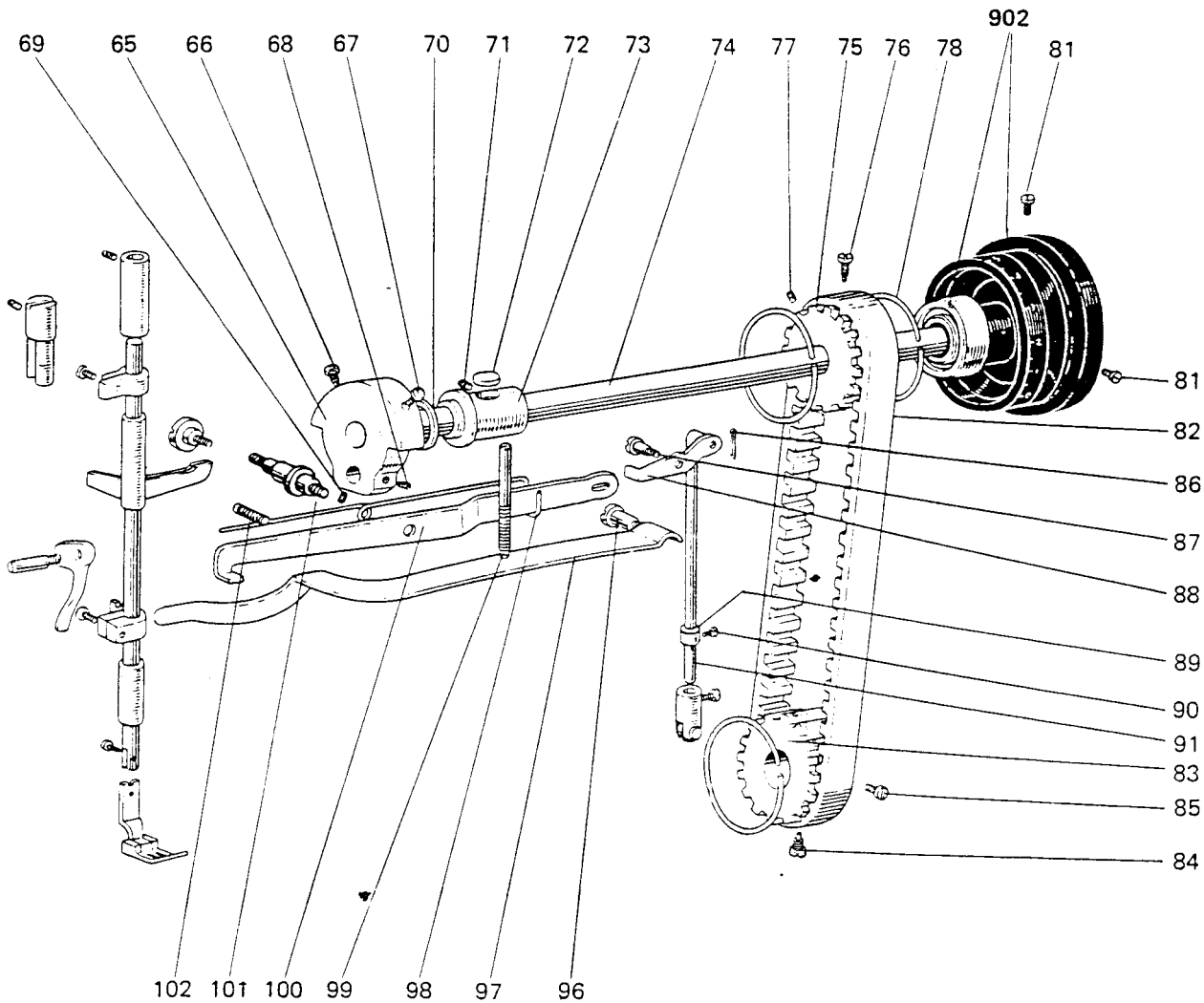

Ref. No.	Part No.	Description
65	A610-G065	Needle bar crank
66	A610-S122	Position screw
67	A610-S121	Screw
68	A610-S110	Set screw
69	A610-S111	Set screw
70	A610-G070	Ring
71	A610-S131	Screw for arm shaft bushing
72	A610-G072	Felt
73	A610-G073	Arm shaft bushing
74	A610-G074	Arm shaft
75	A610-G075	Belt pulley (upper)
76	A610-S104	Screw
77	A610-S109	Screw
78	A610-G078	Spring flange (3)
81	A610-S108	Set screw (2)
82	A610-G082	Timing belt
83	A610-G083	Belt pulley (lower)
84	A610-S115	Screw
85	A610-S114	Screw
902	A610-G902	Machine pulley Assy.
96	A610-S125	Screw
97	A610-G097	Presser spring
98	A610-G098	Lifting lever spring
99	A610-G099	Spring regulating screw
100	A610-G100	Lifting lever
101	A610-G101	Lifting lever hinge screw
102	A610-G102	Spring stop screw

Ref. No.	Part No.	Description
86	A610-G086	Cotter pin
87	A610-S127	Screw
88	A610-G088	Knee lifter lever #2
89	A610-G089	Collar
90	A610-S072	Screw
91	A610-G091	Lifting rod

4. PRESSER FOOT MECHANISM

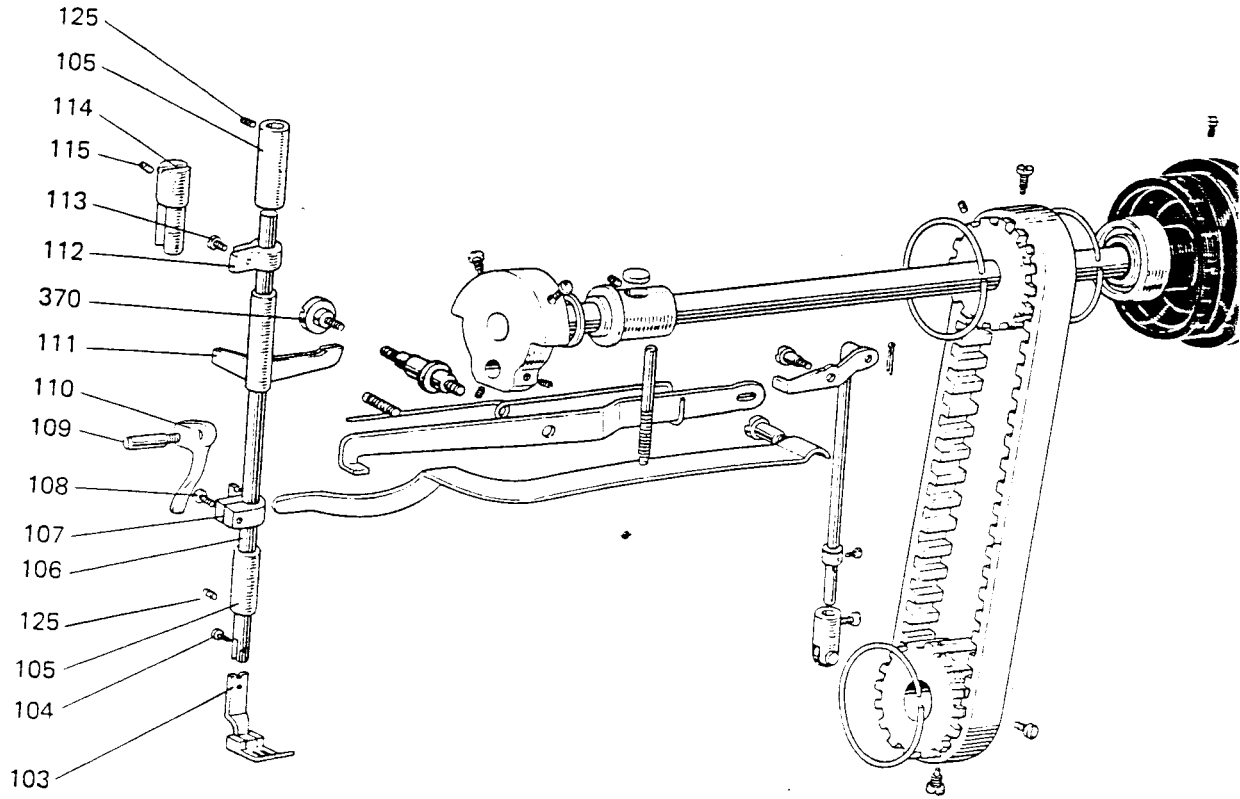

Ref. No.	Part No.	Description
103	A610-GP19	Presser foot (Needle gauge 3/16)
	A610-GP14	Presser foot (Needle gauge 1/4)
104	A610-S100	Screw
105	A610-G105	Presser bar bushing (2)
106	A610-G106	Presser bar
107	A610-G107	Spring bracket
108	A610-S071	Screw
109	A610-G109	Hinge screw
110	A610-G110	Presser bar lifter
111	A610-G111	Releasing lever bracket
112	A610-G112	Presser bar guide lever
113	A610-S079	Pinch screw
114	A610-G114	Presser bar position guide
115	A610-S130	Set screw
370	A610-S126	Hinge screw

Ref. No.	Part No.	Description

5. THREAD TAKE-UP MECHANISM

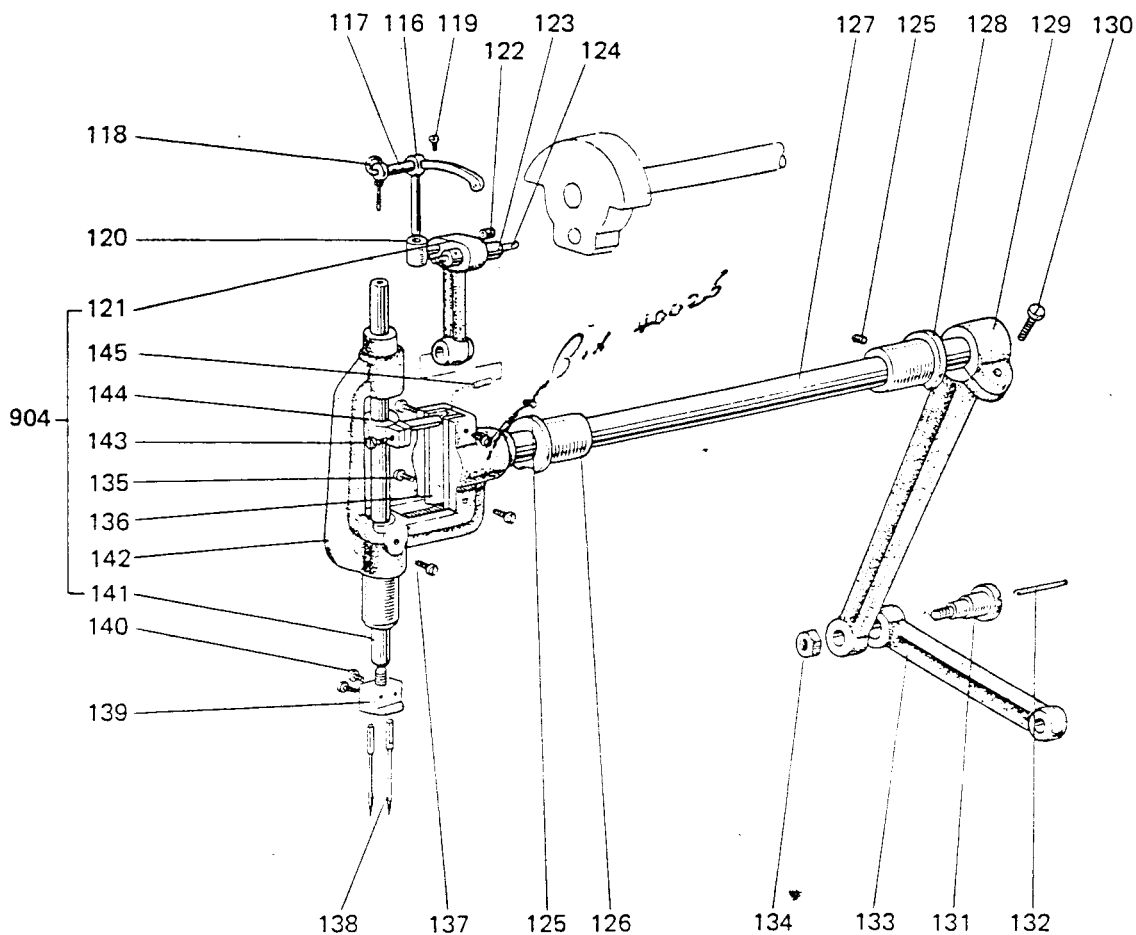

Ref. No.	Part No.	Description
116	A610-G116	Thread take-up lever
117	A610-G117	Take-up lever support stud
118	A610-G118	Oil wick
119	A610-S108	Screw
120	A610-G120	Take-up slide block
121	A610-G121	Needle bar connection link
122	A610-G122	Plug (aluminium)
123	A610-G123	Crank pin
124	A610-G124	Felt
125	A610-S130	Screw (6)
126	A610-G126	Needle bar rock frame rock shaft bushing (left)
127	A610-G127	Needle bar rock frame rock shaft
128	A610-G128	Needle bar rock frame rock shaft bushing (right)
129	A610-G129	Needle bar rock frame rock shaft crank
130	A610-S124	Screw (2)
131	A610-G131	Hinge screw
132	A610-G132	Oil wick
133	A610-G133	Rock shaft crank link

Ref. No.	Part No.	Description
134	A610-N012	Nut
135	A610-S123	Screw (4)
136	A610-G136	Spacer (2)
137	A610-S102	Screw (4)
138	A610-G138	Needle #14 (2)
139	A610-GC19	Needle clamp (Needle gauge 3/16)
	A610-GC14	Needle clamp (Needle gauge 1/4)
140	A610-S084	Set screw (2)
141	A610-G141	Needle bar
142	A610-G142	Needle bar rock frame
143	A610-S071	Screw
144	A610-G144	Needle bar connecting stud
145	A610-G145	Felt
904	A610-G904	Needle bar rock frame Assy.

7. LOWER FEED MECHANISM

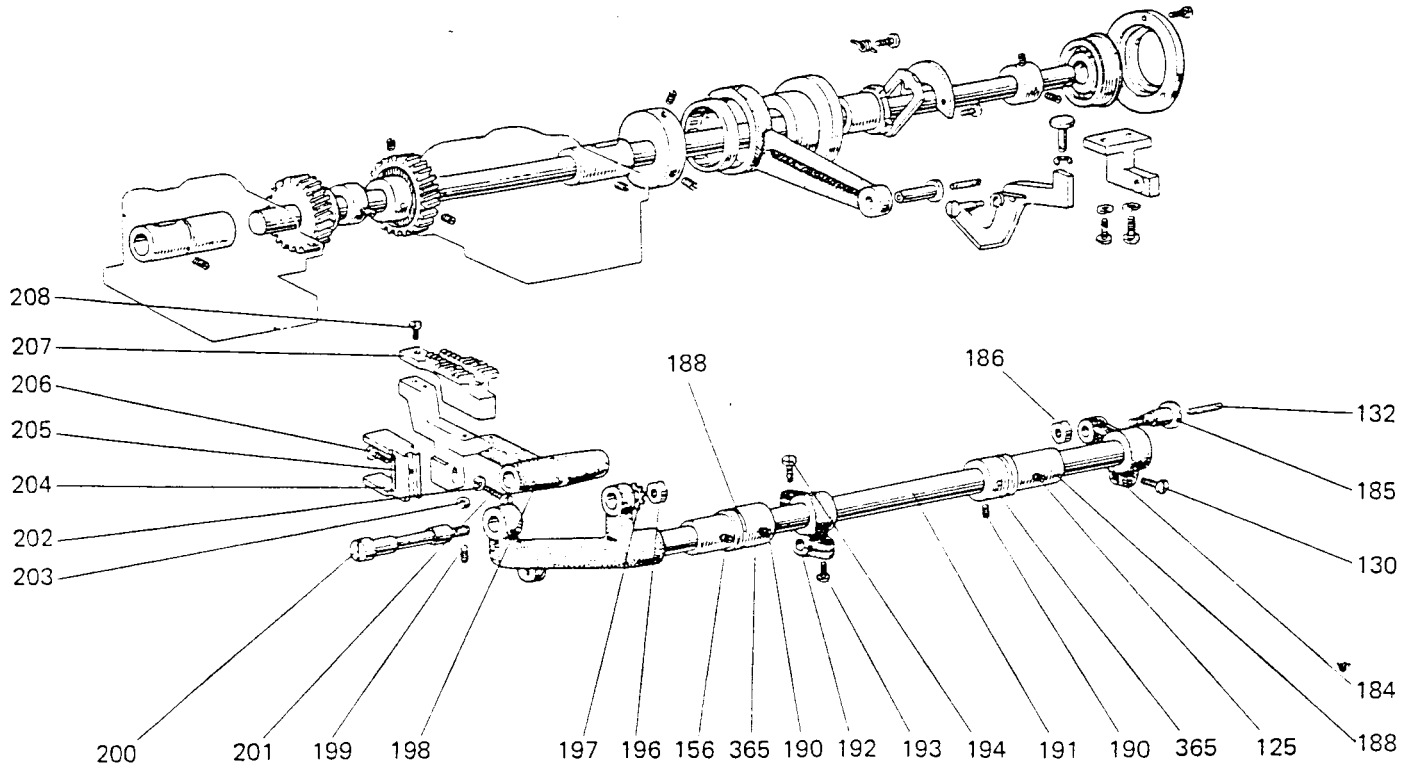

Ref. No.	Part No.	Description
184	A610-G184	Feed lifting crank (right)
185	A610-G131	Screw
186	A610-N012	Nut
188	A610-G188	Feed driving rock shaft bushing(2)
190	A610-S111	Screw (4)
191	A610-G191	Feed driving rock shaft
192	A610-G192	Feed driving crank (left)
193	A610-S124	Screw
194	A610-S097	Screw
196	A610-N013	Nut
197	A610-W002	Washer
198	A610-G198	Feed bar
199	A610-S118	Screw
200	A610-G200	Feed bar hinge stud
201	A610-G201	Screw
202	A610-G202	Washer
203	A610-N011	Nut
204	A610-G204	Feed eccentric fork
205	A610-G205	Felt
206	A610-S101	Screw

Ref. No.	Part No.	Description
207	A610-GD19	Feed dog (Needle gauge 3/16)
	A610-GD14	Feed dog (Needle gauge 1/4)
208	A610-S117	Screw (2)
365	A610-G365	Collar (2)

8. HOOK MECHANISM

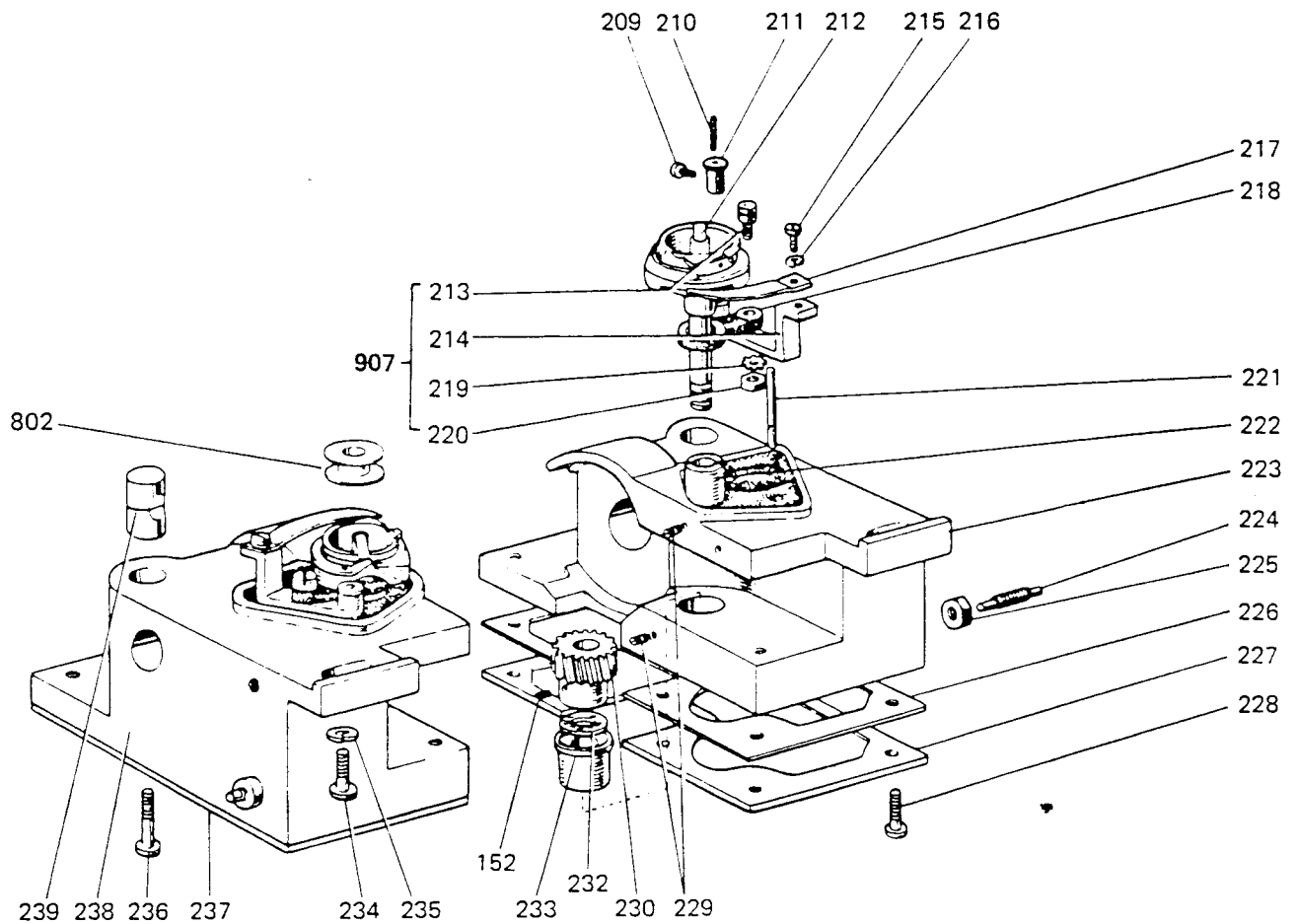

Ref. No.	Part No.	Description	Ref. No.	Part No.	Description
209	A610-S097	Screw (2)	227	A610-G227	Oil cover (hook saddle left)
210	A610-G210	Oil wick (2)	228	A610-S096	Screw (16)
211	A610-G211	Opener supporter (2)	907	A610-G907	Bobbin case opener lever Assy.
212	A610-G212	Rotating hook Assy. (2)	229	A610-S111	Screw (4)
213	A610-G213	Bobbin case opener lever pin (2)	230	A610-G230	Cam shaft gear (small) (2)
214	A610-G214	Bobbin case opener lever (2)	232	A610-G232	Washer (2)
215	A610-S072	Screw (2)	233	A610-G233	Hook driving shaft bushing (lower) (2)
216	A610-G216	Washer (2)	234	A610-S129	Screw (2)
217	A610-G217	Bobbin case opener (2)	235	A610-G235	Washer (2)
218	A610-G218	Bobbin case opener lever link (2)	236	A610-S106	Screw (2)
219	A610-W001	Toothed washer (2)	237	A610-G237	Oil cover
220	A610-N008	Nut (2)	238	A610-G238	Hook saddle (left)
221	A610-G221	Oil gauge (2)	239	A610-G239	Pinching bushing (2)
222	A610-G222	Hook driving shaft bushing (upper) (2)	802	A610-G802	Bobbin (2)
223	A610-G223	Hook saddle (right)			
224	A610-S103	Cock screw (2)			
225	A610-N008	Nut (2)			
226	A610-G226	Gasket (2)			

9. LUBRICATION MECHANISM

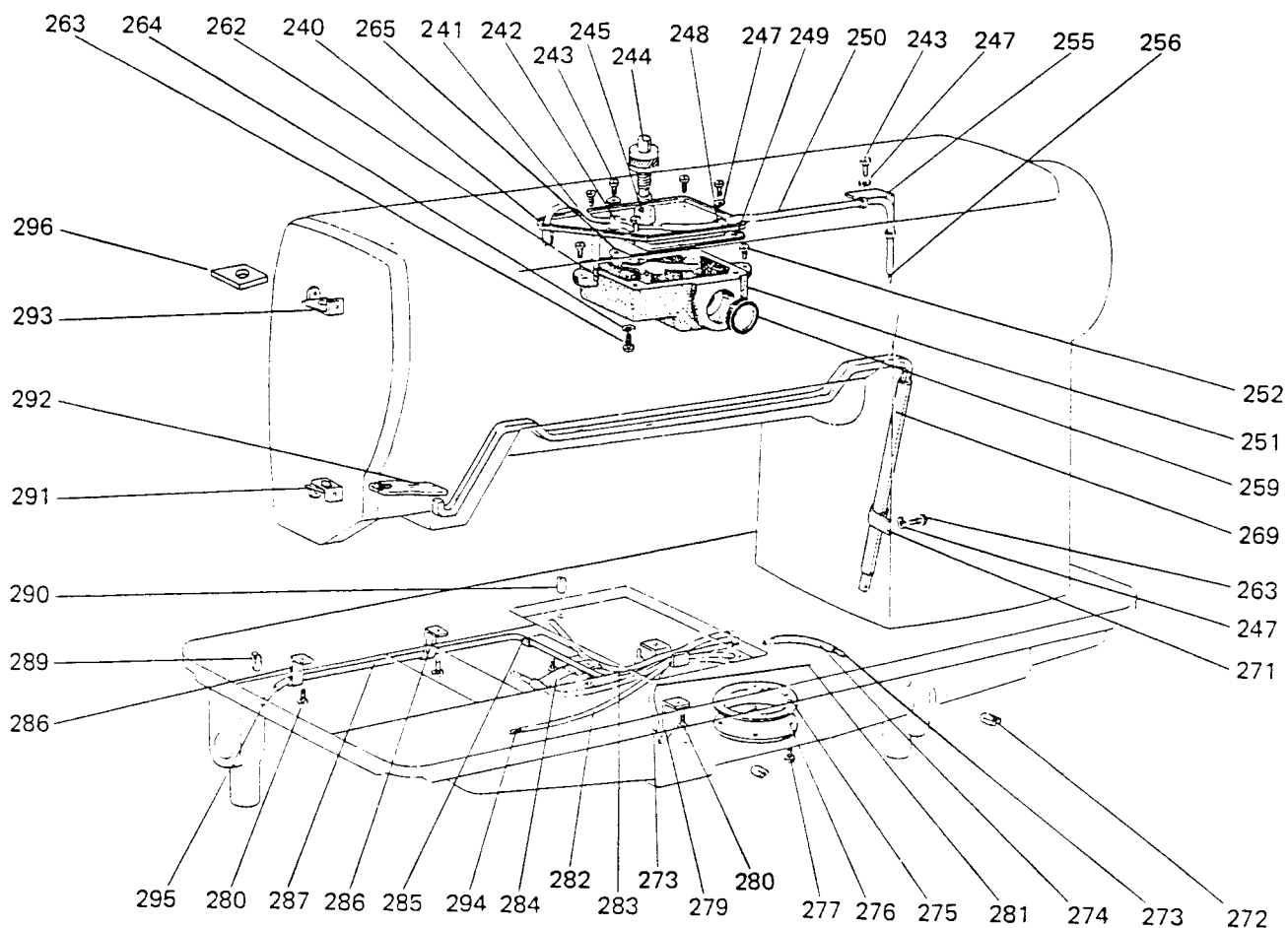

Ref. No.	Part No.	Description	Ref. No.	Part No.	Description
240	A610-G240	Drip pan cover	274	A610-G274	Vinyl tubing (2)
241	A610-G241	Oil wick	275	A610-G275	Packing (B)
242	A610-G242	Tubing holder	276	A610-G276	Cover (B)
243	A610-S074	Screw (6)	277	A610-S093	Screw (4)
244	A610-G244	Oil plunger	279	A610-G279	Tubing holder
245	A610-G245	Bushing	280	A610-S072	Screw (3)
247	A610-G247	Spring washer (8)	281	A610-G281	Vinyl tubing
248	A610-G248	Tubing holder	282	A610-G282	Vinyl tubing
249	A610-G249	Packing	283	A610-G283	Vinyl tubing
250	A610-G250	Vinyl tubing	284	A610-G284	Tubing holder
251	A610-G251	Oil reservoir	285	A610-G285	Tubing holder
252	A610-S071	Screw (2)	286	A610-G286	Tubing holder (2)
255	A610-G255	Tubing holder	287	A610-G287	Vinyl tubing
256	A610-G256	Oil wick	289	A610-G289	Oil wick
259	A610-G259	Oil flow indicator	290	A610-G290	Oil wick
262	A610-G262	Felt	291	A610-G291	Felt holder #2
263	A610-S102	Screw (2)	292	A610-G292	Felt (Needle bar rock frame)
264	A610-G264	Spring washer (2)	293	A610-G293	Felt holder #1
265	A610-G265	Tubing holder	294	A610-G294	Oil wick (2)
269	A610-G269	Vinyl tubing	295	A610-G295	Oil wick
271	A610-G271	Tubing holder			
272	A610-G272	Oil wick (2)			
273	A610-G273	Oil wick (2)			

9. LUBRICATION MECHANISM

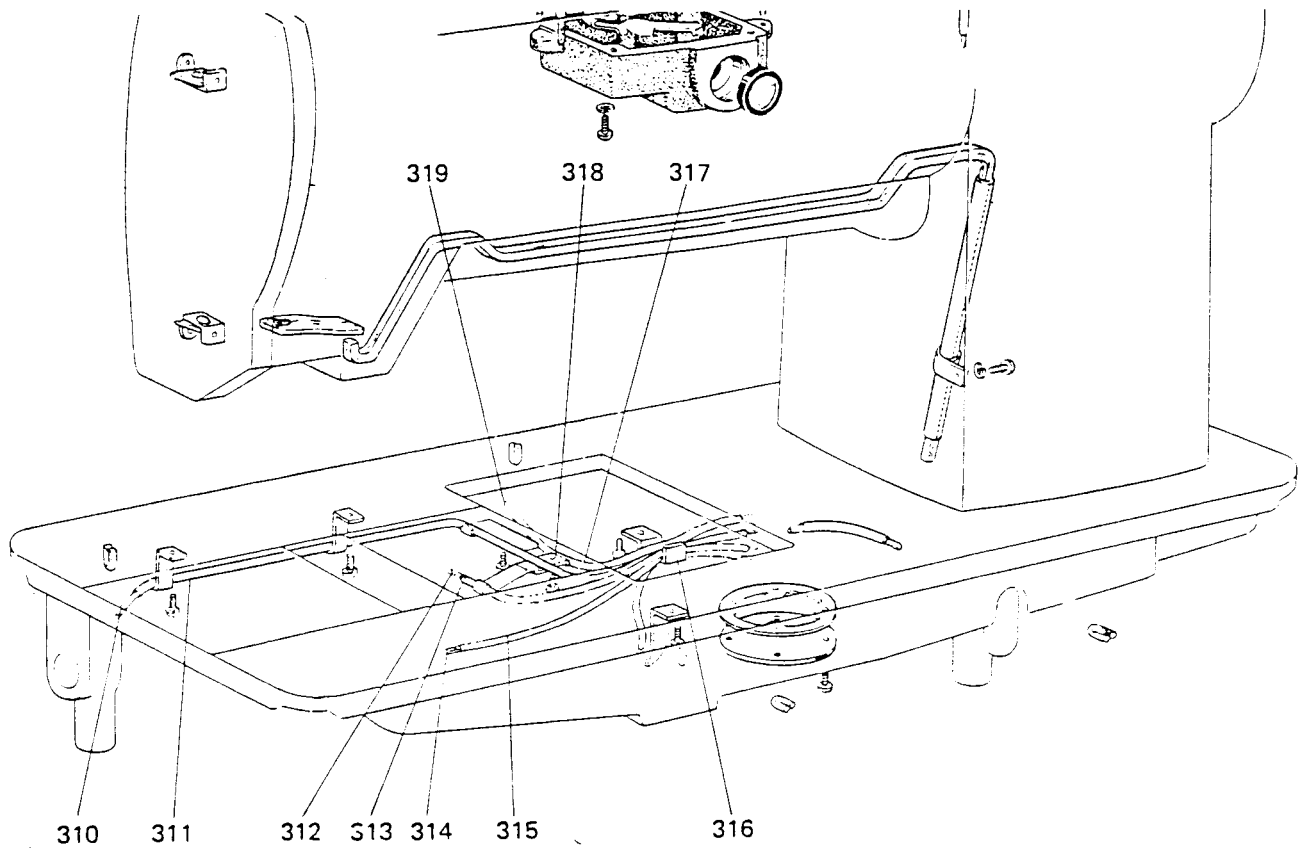

Ref. No.	Part No.	Description	Ref. No.	Part No.	Description
310	A610-G310	Oil wick			
311	A610-G311	Vinyl tubing			
312	A610-G312	Oil wick			
313	A610-G313	Vinyl tubing			
314	A610-G314	Oil wick			
315	A610-G315	Vinyl tubing			
316	A610-G316	Tubing holder			
317	A610-G317	Vinyl tubing			
318	A610-G318	Tubing holder (2)			
319	A610-G319	Oil wick			

10. REVERSE LEVER MECHANISM

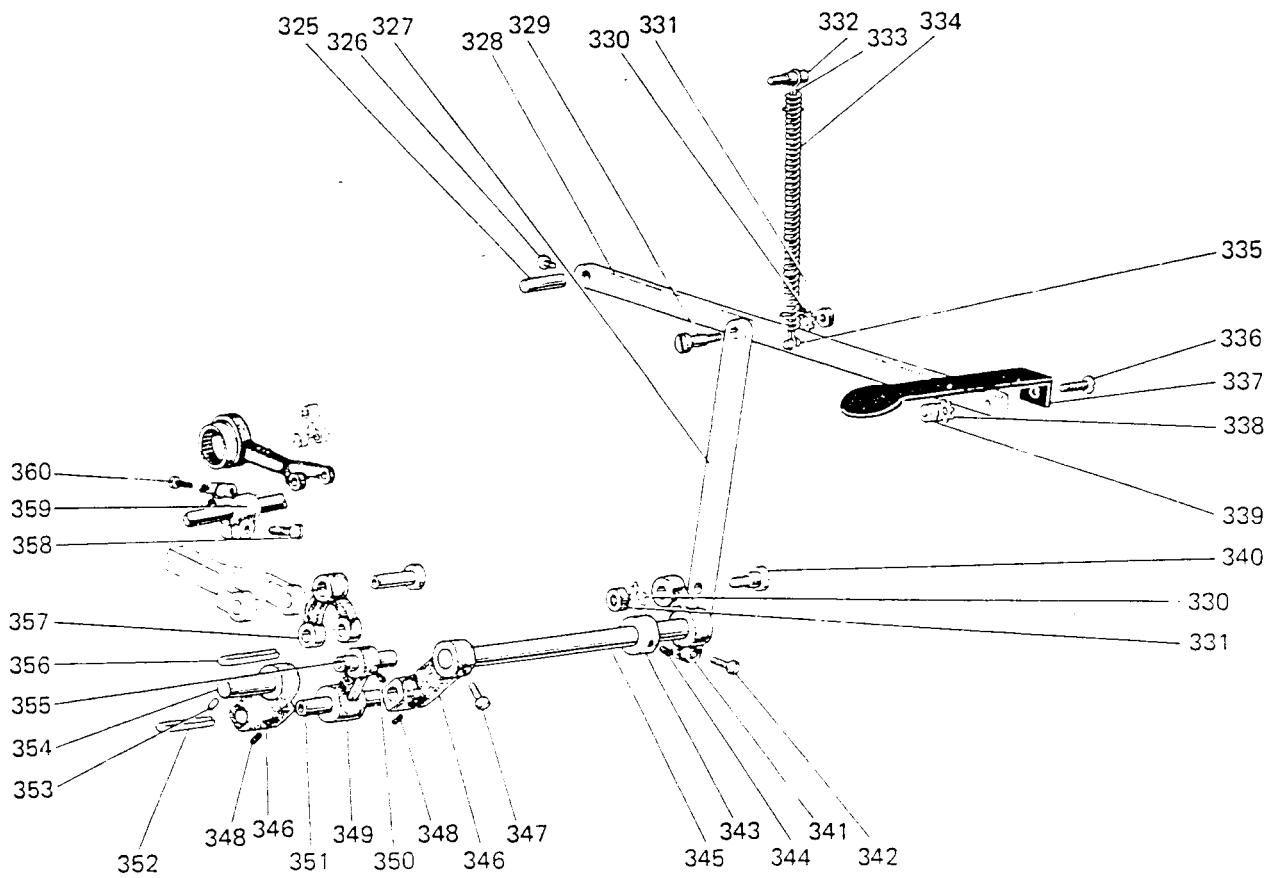

Ref. No.	Part No.	Description	Ref. No.	Part No.	Description
325	A610-G325	Pin	345	A610-G345	Reverse stitch shaft
326	A610-S074	Screw	346	A610-G346	Reverse stitch shaft crank (left)(2)
327	A610-G327	Reverse lever connecting plate	347	A610-S104	Screw
328	A610-G328	Reverse stitch lever	348	A610-S140	Screw (2)
329	A610-G329	Hinge screw	349	A610-G349	Bell crank
330	A610-W002	Lock washer (2)	350	A610-S099	Screw
331	A610-N009	Nut (2)	351	A610-G351	Pin
332	A610-G332	Spring guide pin	352	A610-G352	Oil wick
333	A610-G333	Hook for spring (2)	353	A610-S130	Screw
334	A610-G334	Coil spring	354	A610-G354	Pin
335	A610-G335	Pin for spring	355	A610-G355	Pin
336	A610-S095	Screw	356	A610-G356	Oil wick
337	A610-G337	Reverse stitch plate	357	A610-G357	Link
338	A610-W001	Lock washer	358	A610-S124	Screw
339	A610-N007	Nut	359	A610-G359	Feed arm (left)
340	A610-G340	Hinge screw	360	A610-S097	Screw
341	A610-G341	Reverse stitch shaft crank(right)			
342	A610-G342	Screw			
343	A610-G343	Collar			
344	A610-S110	Screw (2)			

11. ACCESSORIES (ACCESSORIES BOX)

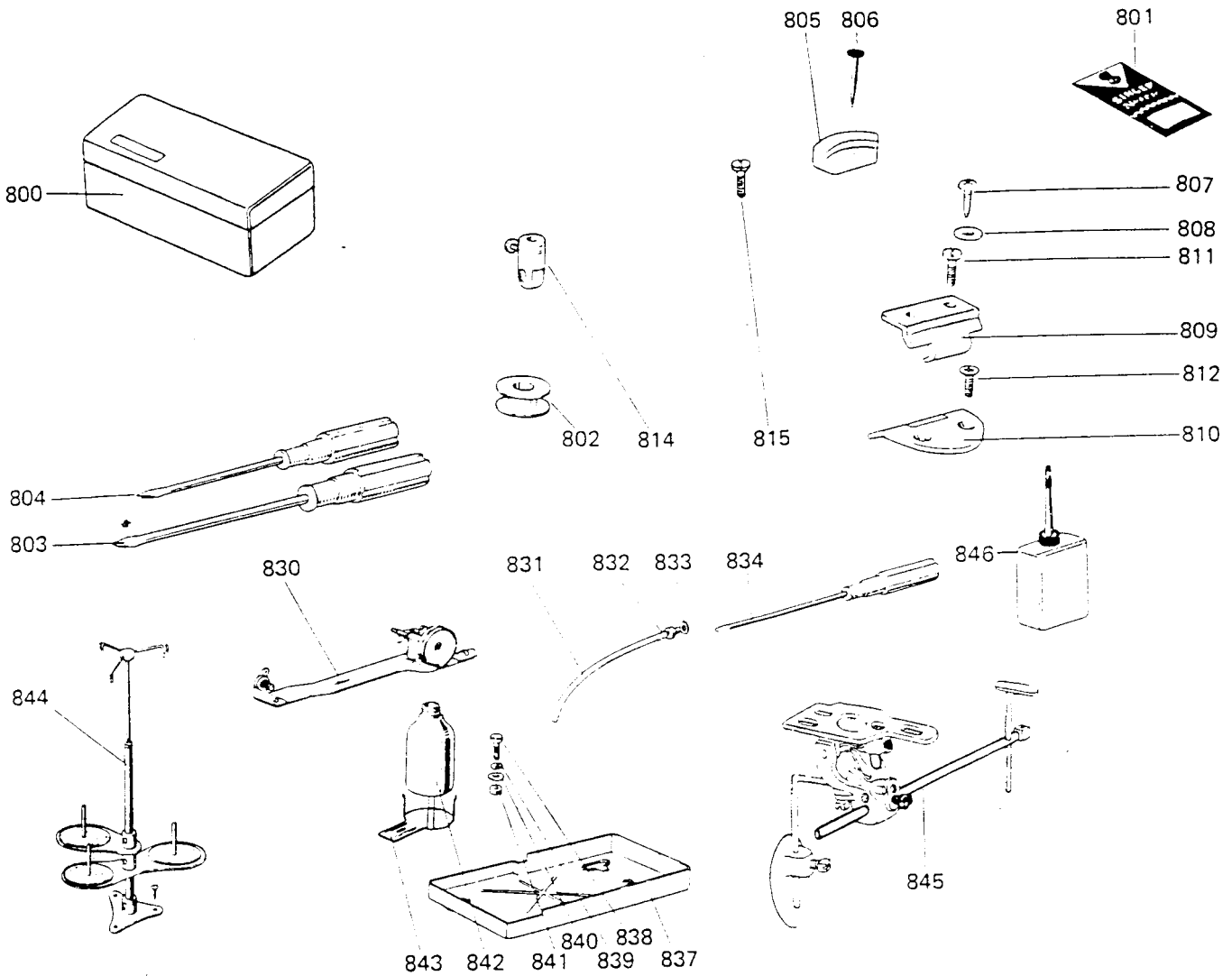

Ref. No.	Part No.	Description	Ref. No.	Part No.	Description
800	A610-G800	Accessories box	834	A610-G834	Screw driver (large)
801	A610-G801	Needle #14 (10)	837	A610-G837	Oil pan
802	A610-G802	Bobbin (4)	838	A610-G838	Bolt
803	A610-G803	Screw driver (medium)	839	A610-G839	Spring washer
804	A610-G804	Screw driver (small)	840	A610-G840	Washer
805	A610-G805	Vibration preventing rubber (4)	841	A610-G841	Nut
806	A610-G806	Nail (9)	842	A610-G842	Oil bottle
807	A610-G807	Screw (2)	843	A610-G843	Oil bottle holder
808	A610-G808	Washer (2)	844	A610-G844	Cotton stand assembly
809	A610-G809	Hinge hook (2)	845	A610-G845	Knee lifter (set)
810	A610-G810	Hinge plate (2)	846	A610-G846	Oiler (large)
811	A610-G811	Screw (4)			
812	A610-G812	Screw (4)			
814	A610-G814	Roller (set)			
815	A610-G815	Screw (2)			
830	A610-G830	Bobbin winder Assy.			
831	A610-G831	Vinyl tubing			
832	A610-G832	Screw bushing			
833	A610-G833	Packing			

OPERATIONS GUIDE

Principal parts of Model 312T Machine

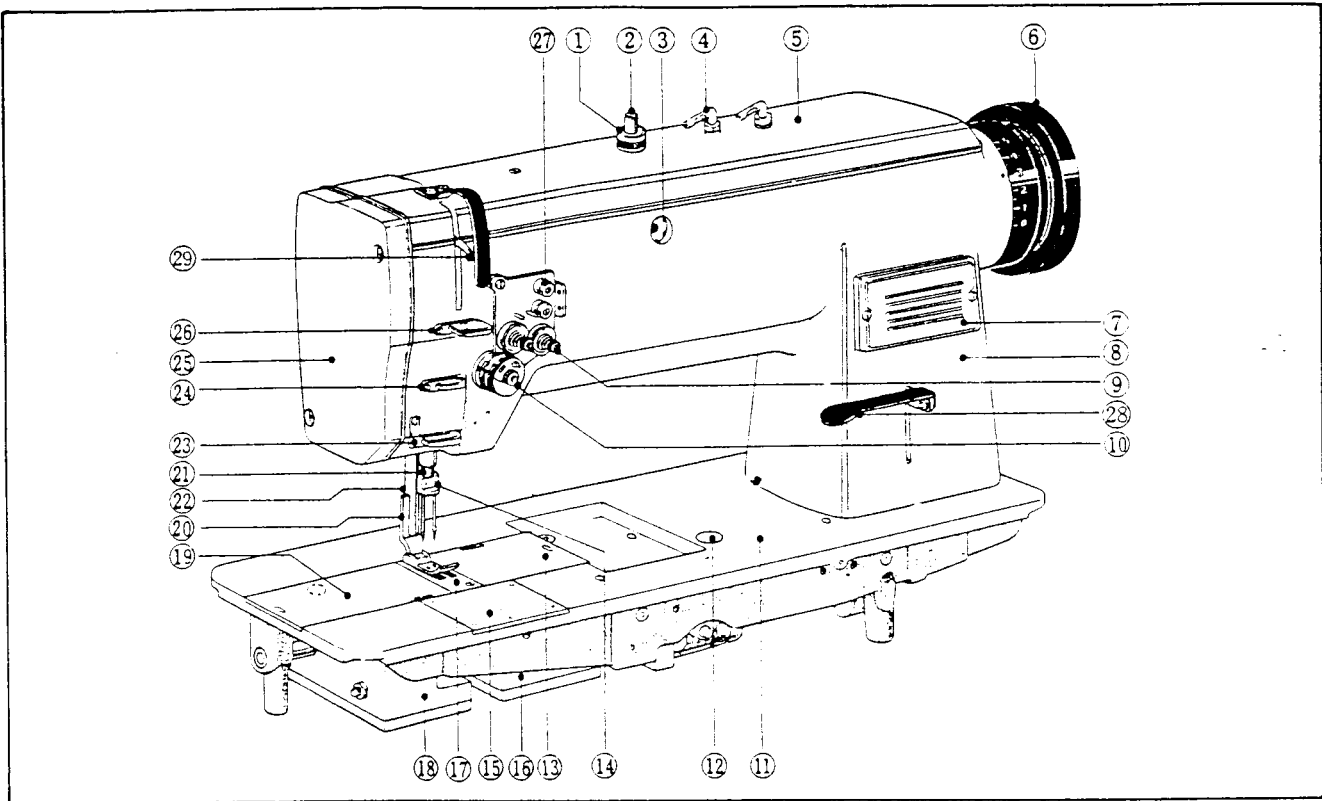

- | | | |
|------------------------------------|-----------------------------------|----------------------------|
| 1) Press stud for oil plunger. | 11) Bed. | 21) Needle bar. |
| 2) Press bar for oil plunger. | 12) Stitch regulator push button. | 22) Presser bar. |
| 3) Oil level indicator. | 13) Slide plate (right). | 23) Thread guide (lower). |
| 4) Thread guide (top of arm). | 14) Needle clamp | 24) Thread guide (middle). |
| 5) Arm top cover. | 15) Slide plate (front). | 25) Face plate. |
| 6) Machine pulley. | 16) Hook saddle. (right) | 26) Thread guide (upper). |
| 7) Front cover. | 17) Throat plate. | 27) Pre-tension. |
| 8) Arm | 18) Hook saddle. (left) | 28) Feed reverse lever |
| 9) Upper thread tension regulator. | 19) Slide plate. (left) | 29) Thread take-up lever |
| 10) Thread controller. | 20) Presser foot. | |

How to install and adjust the knee lifter

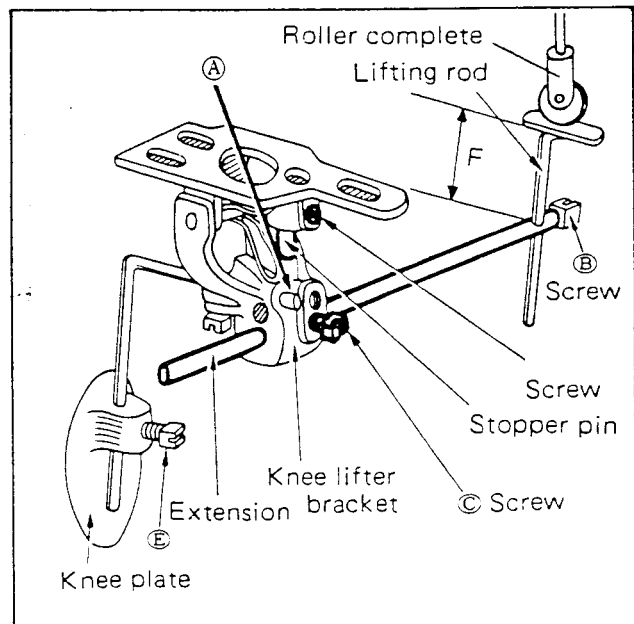
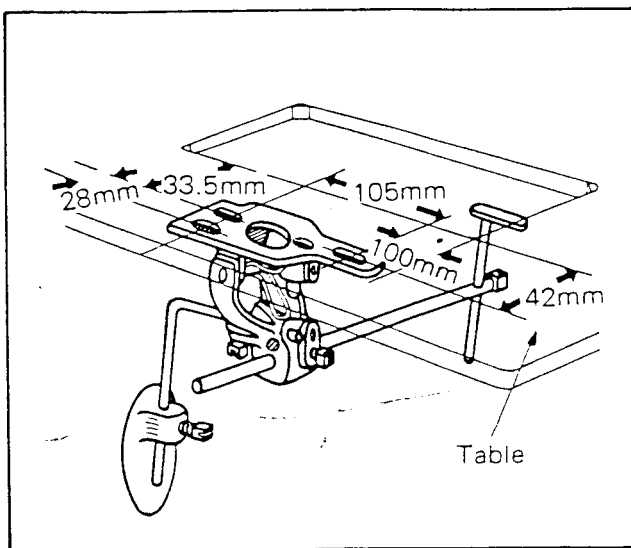

How to use the machine

1. To set the needles

Caution: Before making the following adjustment, be sure to turn off the power source switch.

Insert the needles into the needle clamp as far as they will go, with the long grooves facing each other. Then tighten the needle clamp screws.

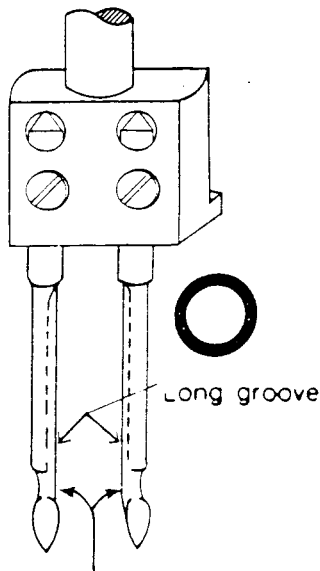

Insufficient insertion

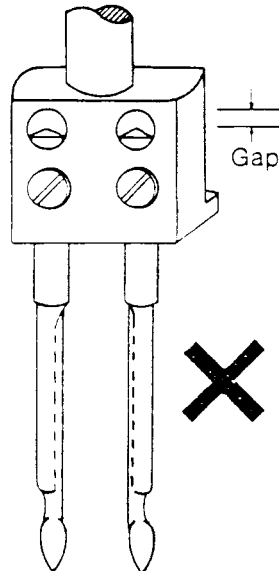

Needles facing the wrong direction.

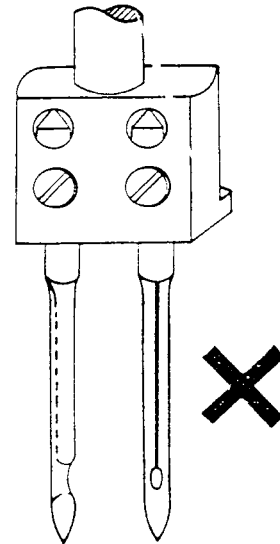

2. To wind the bobbin

- When winding a bobbin with fine thread such as nylon or tetron threads, the bobbin should be wound loosely using a light tension.
- If bobbin does not wind evenly, move tension bracket to the left or right as required. If bobbin winds high on right, move bracket to left, and if bobbin winds high on left, move bracket to right.
- Bobbin should be wound to $\frac{4}{5}$ of its capacity. For more thread on the bobbin, turn adjusting screw clockwise; for less thread, turn screw counterclockwise.

Note: Be sure to raise the presser foot when running the machine without material under the foot.

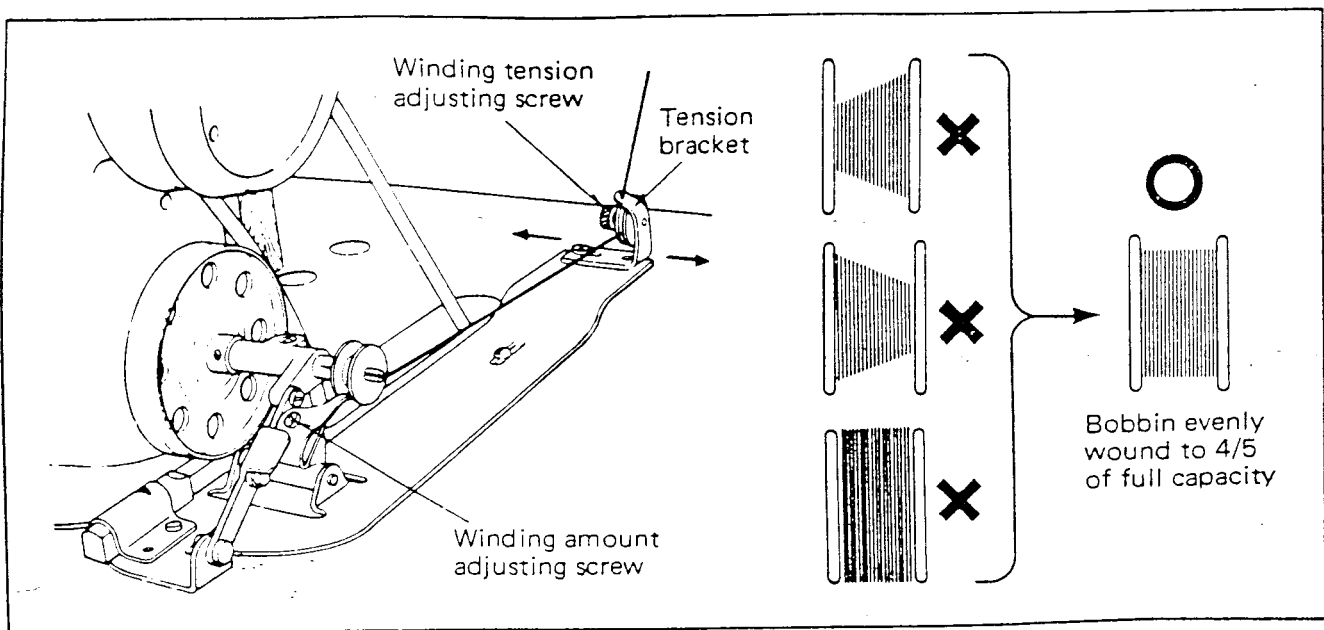

How to use the machine

3. Threading the machine

Note: The thread guide (A) should be positioned just above the thread spool.

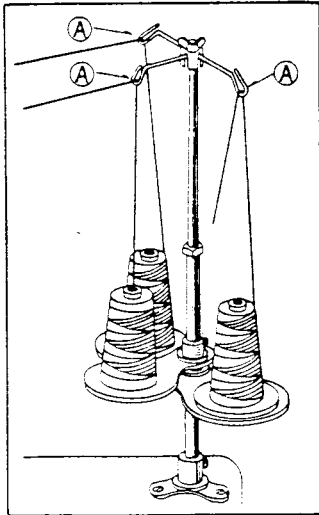

Raise the thread take-up lever to its highest position and pass the needle thread from the thread stand through threading points in the order shown below.

4. To adjust stitch length

Stitch length adjustment is achieved simply by depressing a button in the machine bed and turning the machine pulley.

1. Depress button and turn machine pulley slowly toward you until button sinks further into the machine bed and the machine pulley stops.
2. Depress the button harder and turn machine pulley toward you, or away from you, to set stitch length graduation on the marking on arm. Release the button when desired setting is obtained.

Caution: NEVER depress the button while the machine is running.

To change the direction of feed for back tacking, depress feed reverse lever to lowest position until back tack is completed.

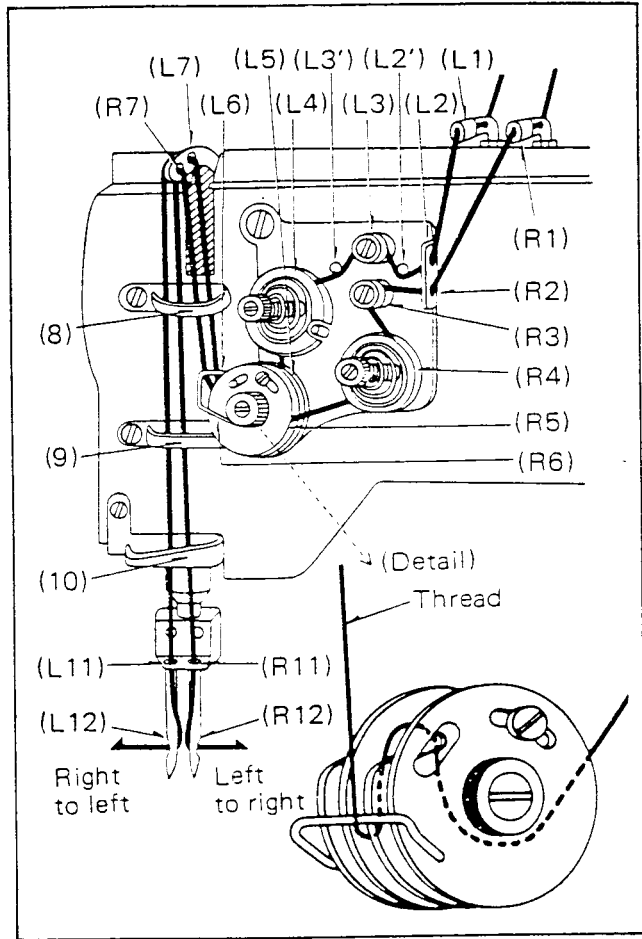
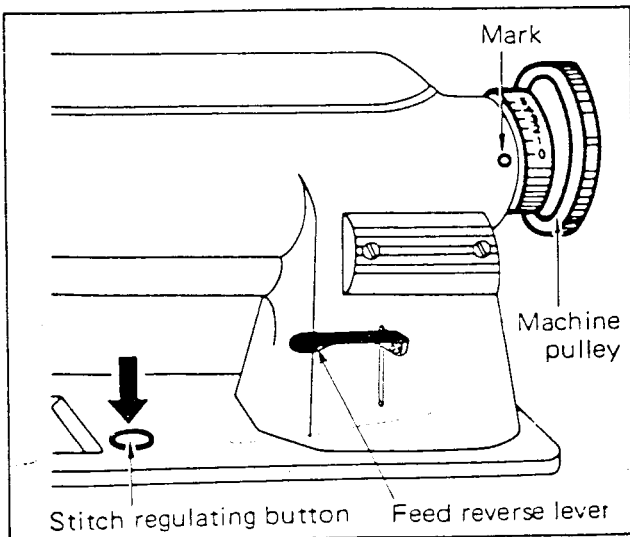

5. To replace the bobbin

Hold bobbin so that thread will unwind in the direction shown in illustration below and place it in the bobbin case.

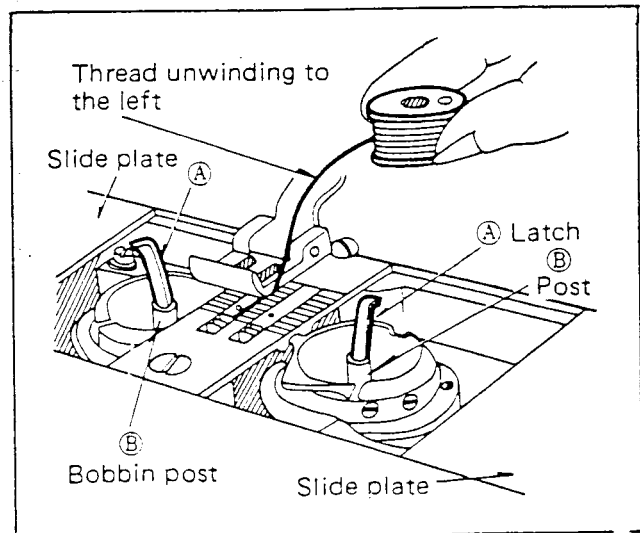

How to use the machine

6. Threading the bobbin case

- 1) Pull thread into slot ① in bobbin case and draw it through between horn ② and bobbin case opener.

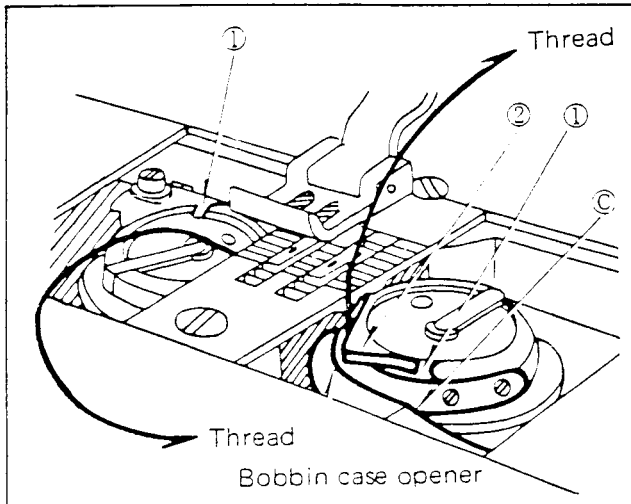

- 2) Hold needle threads with left hand and turn machine pulley until needles bring up bobbin threads. Pull ends of bobbin threads up through throat plate and place both needle and bobbin threads diagonally under presser foot.

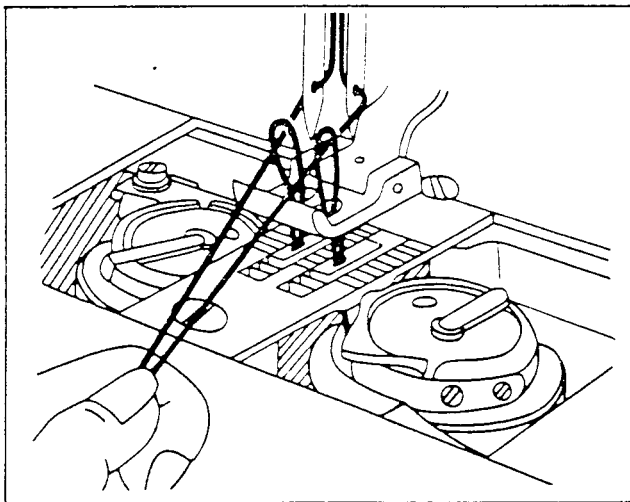

9. Bobbin thread tension

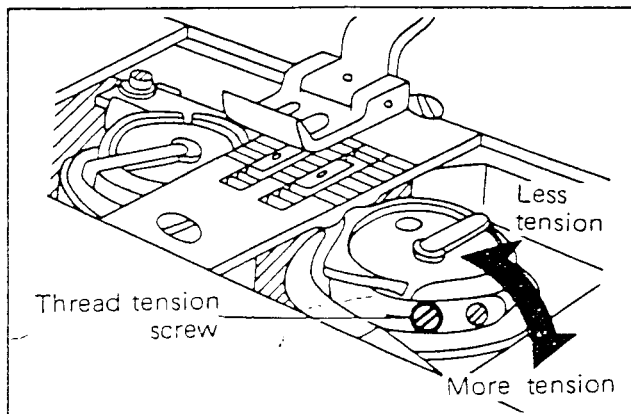

7. Adjustment of thread tension

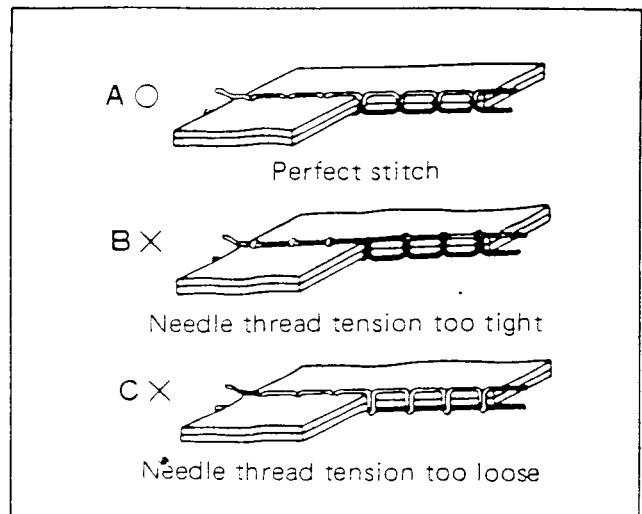

8. Needle thread tension

- Needle thread is adjusted according to the bobbin thread tension.
- Needle thread tension is adjusted by tension regulating thumb nut.

For special fabric sewing with special thread, the desired tension can be obtained by adjusting the tension and range of movement of the take-up spring.

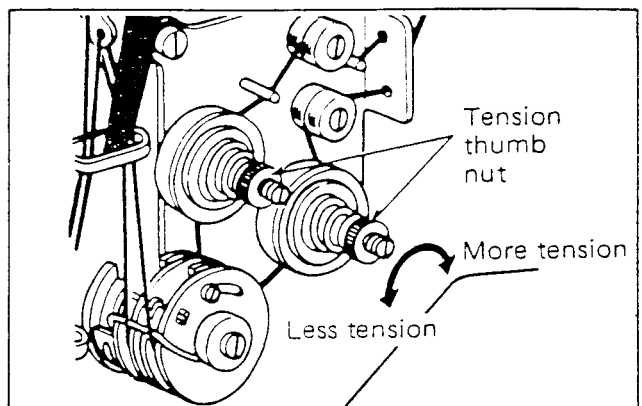

10. Adjustment of presser foot pressure

Pressure on the presser foot is to be adjusted in accordance with materials to be sewn.

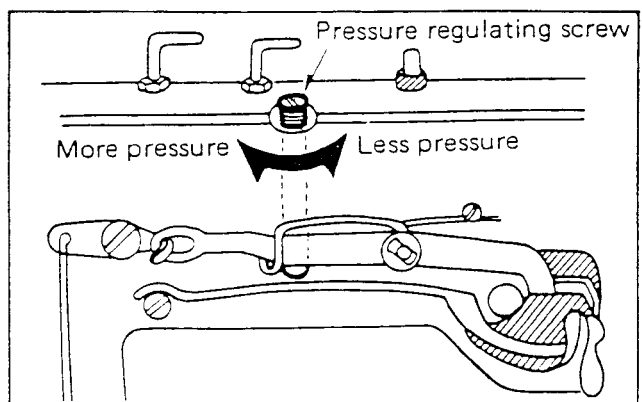

Trouble & Repair

Trouble	Causes	Corrective Action
Skip Stitching	1) Needle o Bent needle o Not suited for thread being used	Change the needle with a new one. Replace with needle suited for thread being used.
	2) Improperly set needle o Insufficient insertion o Incorrectly inserted needle	Insert properly as instructed in manual. Set needle holes parallel to front edge of bed. Set the needles with long grooves facing each other.
Loose Stitches	1) Needle thread tension too loose	Turn tension regulating thumb nut clockwise to increase tension.
	2) Take-up spring tension too weak	Turn tension stud clockwise to increase tension.
	3) Bobbin thread tension too loose	Turn bobbin case tension screw clockwise to increase tension.
Thread Breakages	1) Poor quality thread	Use better quality thread.
	2) Needle o Bent needle o Improperly set needle o Needle too small for thread being used	Change the needle with a new one. See item 2) of skip Stitching. Replace with correct size needle for thread being used.
	3) Needle thread tension too tight o Lint accumulated between tension discs o Uneven or over wound bobbin o Lint accumulated in bobbin case o Broken or bent bobbin case tension spring o Improperly inserted bobbin	Turn tension regulating thumb nut counterclockwise to decrease tension. Remove thumb nut and tension discs and clean with a lint brush. Replace with bobbin evenly wound to 4/5 of its full capacity. Remove bobbin case and clean with a lint brush. Replace with a new one. Insert bobbin correctly so that it will rotate in counterclockwise direction when the thread is pulled out.
Puckering	1) Size of needle and thread incorrect for fabric being sewn	Use correct size needle and thread for the fabric being sewn.
	2) Needle and bobbin thread tensions too tight	Adjust needle thread tension by adjusting tension thumb nut and take-up spring. Adjust bobbin thread tension by turning tension screw.
	3) Excessive presser foot pressure	Decrease pressure on presser foot by turning pressure regulating screw counterclockwise.

Before Starting the machine

1 Lubrication-1

Before starting the machine, the oil reservoirs shown in illustration below must be filled with oil. Run machine at a moderate speed for 10 to 15 minutes until the oil is circulated to all parts in movable contact.

1) Arm oil reservoir

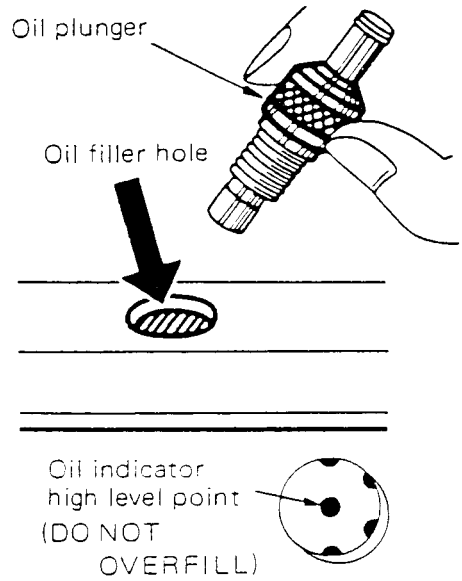

Be sure to depress the press bar for oil plunger when using the machine

Depress press stud to raise press bar when machine is not in use.

Press stud

Lubrication-2

Apply 5 - 6 drops of oil to areas indicated with

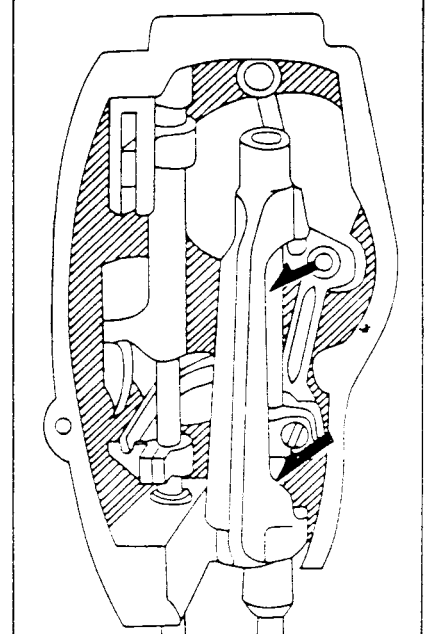

2) Bed oil reservoir

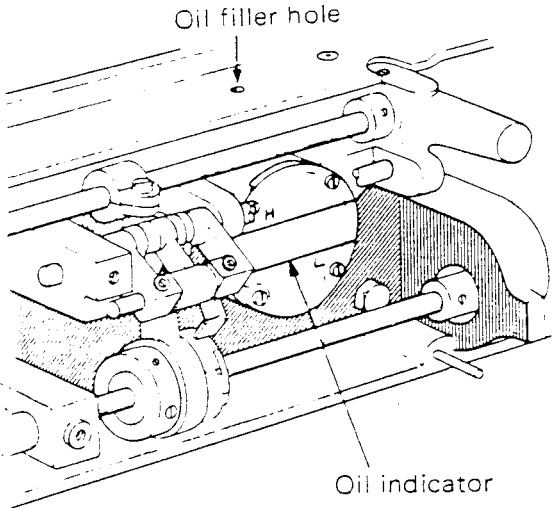

Open slide plate (A) and apply oil to all wicks just under the slide plate.

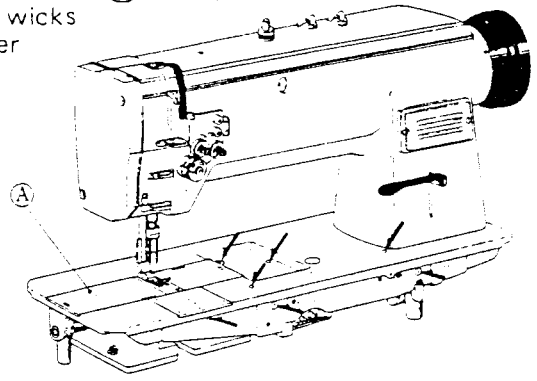

2. Adjustment of rotating hook oil flow regulator

3) Hook saddle oil reservoir (left & right)

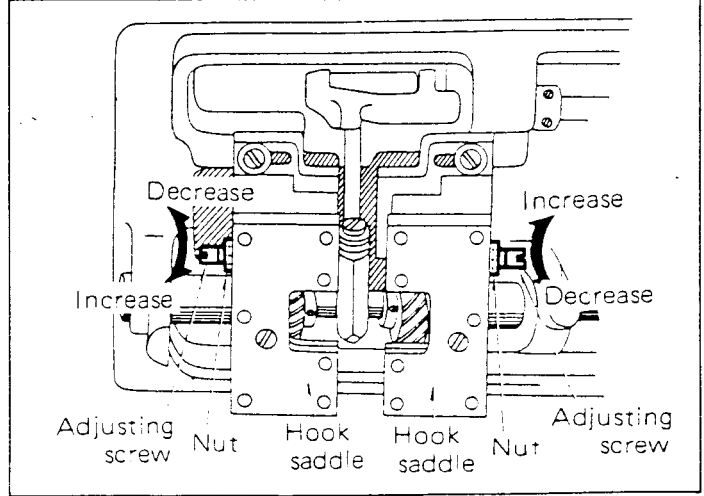
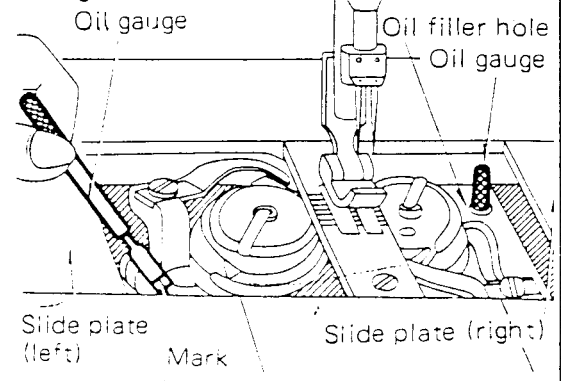

Cleaning

Machine should be periodically cleaned with small brush to remove all lint and other waste which accumulates around the hooks, throat plate, feed dog, thread tension regulator and thread controller disc:

Installation of rubber cushions

Four rubber cushions are used to prevent excessive vibration and noise of the machine. These are fitted in the four corners of the table cut-out.

- o Cut 20mm (13/16") radius and 13mm (1/2") deep seats for the rubber cushions as shown in the diagram, paying particular attention to the depth of corners.
- o Fasten the rubber cushions to the four corners of the table cut-out with nails as shown in the diagram.

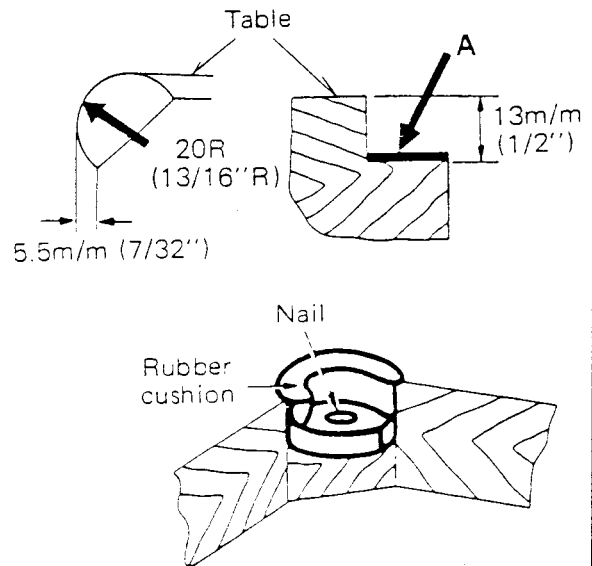

Specifications

Number of needles	Two
Speed	3,500 s.p.m.
Rotary hook	Regular size
Max. stitch length	5mm (5 s.p.i.)
Needle bar stroke	33.4mm (1-5/16")
Presser foot lift	7.2mm (9/32")
Space at right of needle	245mm (9-11/16")
Needles	CAT. No. 1901 #14
Feed reverse lever	Hand or foot operated
Gauges (Standard)	4.8mm (3/16") and 6.4mm (1/4")
Bed dimensions	517mmx178mm (20-3/8"x 7")

TABLE CUT-OUT

ALL DIMENSIONS IN MILLIMETERS (mm)

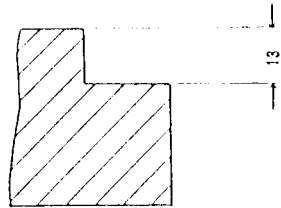
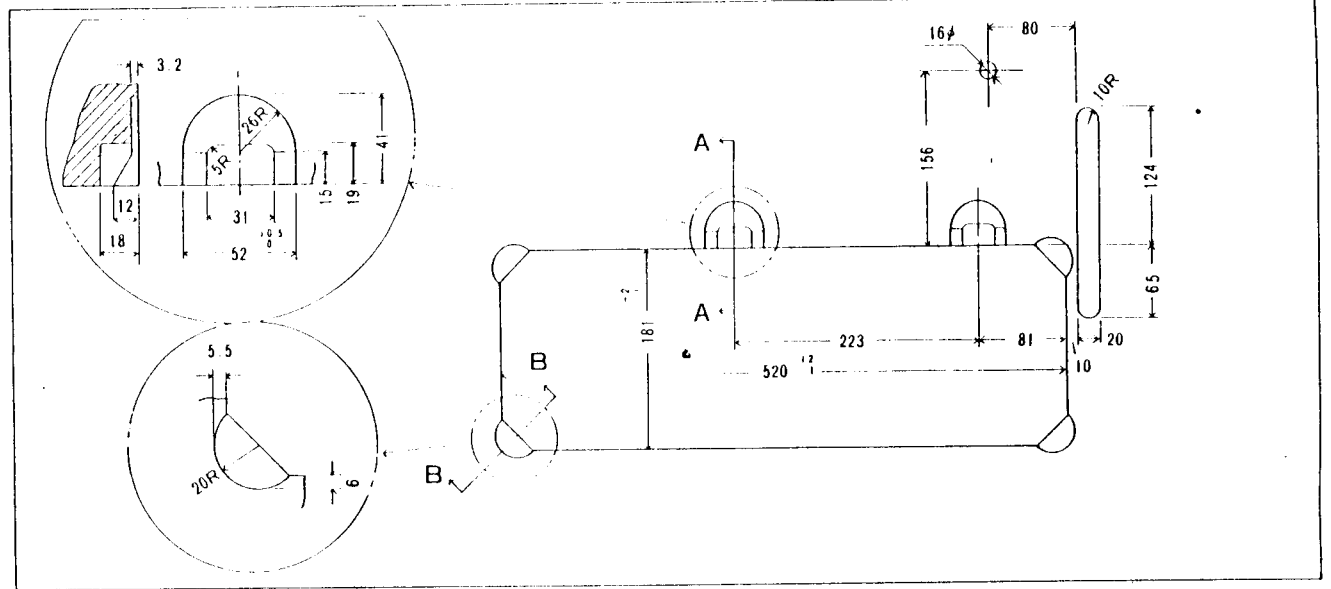
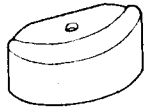
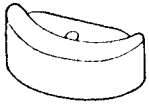
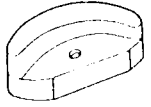
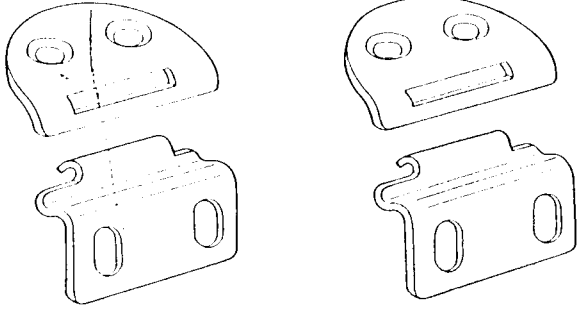

SECTION B

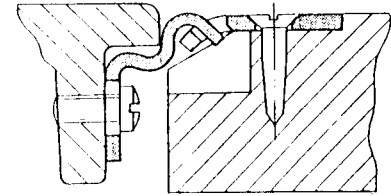

SECTION A