

SINGER
885-113

THE SINGER 885-113 MACHINE

Description

The 885-113 machine is designed for application in the trimming and setting of shoulder pads in suits and coats. It is similar to the 1110117 machine except in the following respects:

- a. Modification has been made to provide $2\frac{1}{2}$ SPI as compared to 3 SPI.
- b. Two needle thread tensions are provided.
- c. A special adjustable tension release to compensate for varying material thickness has been incorporated.
- d. Maximum recommended speed is 1100 RPM.

Adjustments

Tension Release Bracket

With no material under the presser foot, the lifting presser foot should raise approximately $1/16$ " when the tension release pin engages the tension release bracket to open the tension discs on Tension "A"- Figure 1.

If adjustment is required, loosen Screw "C"- Figure 2 and move the tension release bracket up or down to make the tension discs open earlier or later.

Needle Thread Tensions

Tension "B"- Figure 1 maintains sufficient control on the needle

FIGURE 1

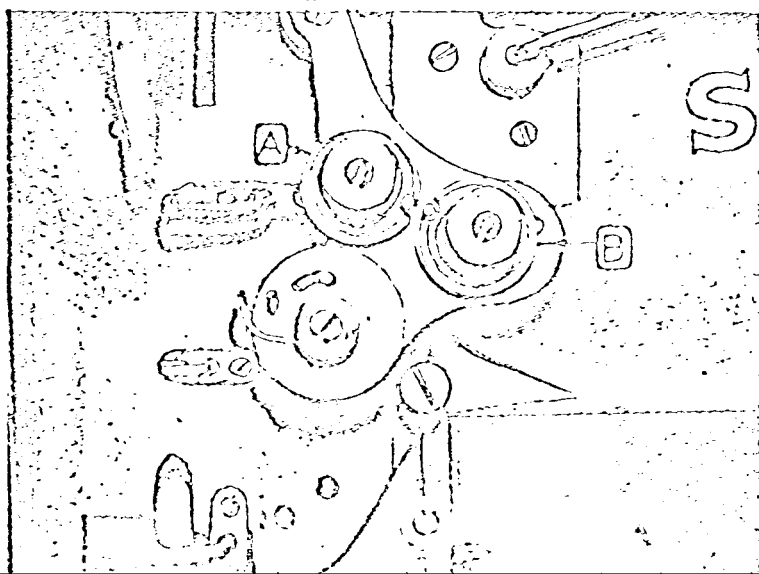
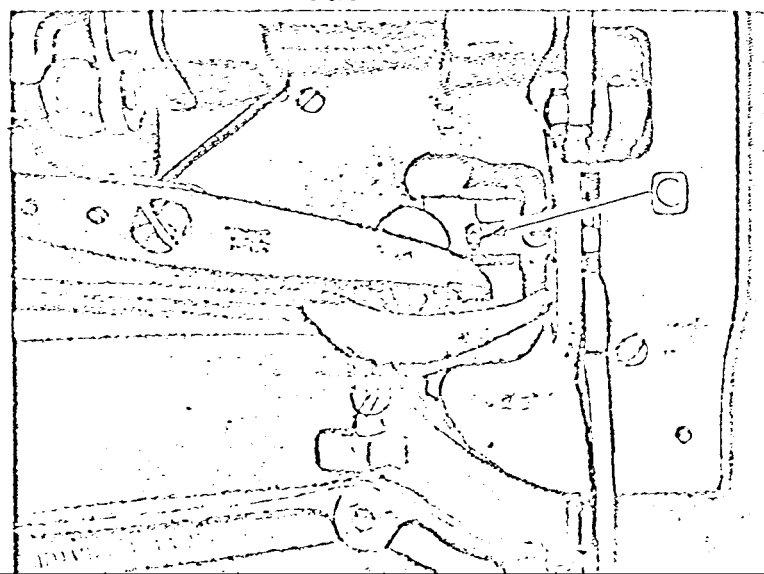

FIGURE 2



THE SINGER 885-113 MACHINE

Single Needle, Lockstitch, Compound Feed, Vertical Trimmer
 (111G117 Converted for 2 1/2 Stitches Per Inch)

126X11

MAXIMUM RECOMMENDED MACHINE SPEED: 1100 RPM. NEEDLE CAT. #4506 #2

Parts List

<i>ALTERED</i>	Tension Complete	223705	
	Tension Release Pin	235576	
	Foot Lifter Lever Spring	227561	
	Needle Bar Rock Frame Crank Pinch Screw	200029	
<i>ALTERED</i>	Feed Driving Connection Cap Screw	494230-001	
<i>ALTERED</i>	Feed Dog	491716	Specify Gaus
<i>ALTERED</i>	Vibrating Presser Foot	491717	Specify Gaus
<i>ALTERED</i>	Feed Driving Rock Shaft Crank	492065-001	
<i>NEW</i>	Throat Plate Body	492065-002	Specify Gaus
<i>ALTERED</i>	Needle Bar Rock Frame Rock Shaft Crank	492065-003	
<i>NEW</i>	Needle Bar	492065-004	
<i>ALTERED</i>			
<i>NEW</i>	Actuator Finger Insert	492065-007	
<i>ALTERED</i>	Presser Bar Lifting Bracket	492065-006	
<i>ALTERED</i>	Feed Driving Rock Shaft	492065-009	
	Throat Plate Knife Cutting Bar (1/8)	491718008	
	Throat Plate Knife Cutting Bar (5/32)	491718010	
	Throat Plate Knife Cutting Bar (3/16)	491718012	
<i>ALTERED</i>	Throat Plate Knife Cutting Bar (1/4)	491718016	
	Throat Plate Knife Cutting Bar (9/32)	491718018	
	Throat Plate Knife Cutting Bar (5/16)	491718020	
	Throat Plate Knife Cutting Bar (3/8)	491718024	
	Lifting Presser Foot (1/8 & 5/32)	491727008	
	Lifting Presser Foot (3/16)	491727012	
<i>ALTERED</i>	Lifting Presser Foot (1/4)	491727016	
	Lifting Presser Foot (9/32 & 5/16)	491727018	
	Lifting Presser Foot (3/8)	491727024	

The Singer Company
 Industrial Products Division
 Mechanized Systems Department

Clifton Laboratory
 Clifton, N. J.
 1/18/66

Black ... ALTERED in machine - PARTS NOT INTERCHANGEABLE

Red ... REMOVED FROM MACHINE ... ALTERED TO PRINT

Blue ... NEW PARTS MADE TO PRINT

Adjustments (cont.)

thread while Tension "A"- Figure 1 is released. The setting of this tension is generally very light.

PARTS LIST

<u>Description</u>	<u>Part No.</u>
Tension Complete	223705
Tension Release Pin	235576
Foot Lifter Lever Spring	227561
Needle Bar Rock Frame Crank Pinch Screw	200029
Feed Driving Connection Cap Screw	494230-001
Feed Dog	491716 (Spec. Gauge)
Vibrating Presser Foot	491717 (Spec. Gauge)
Feed Driving Rock Shaft Crank	492065-001
Throat Plate Body	492065-002 (Spec. Gauge)
Needle Bar Rock Frame Rock Shaft Crank	492065-003
Feed Bar	492065-004
Needle Bar Rock Frame Rock Shaft Crank Connection	492065-005
Presser Bar Lifting Bracket	492065-006
Actuator Finger Insert	492065-007
Feed Driving Connection	492065-008
Feed Driving Rock Shaft	492065-009
Throat Plate Knife Cutting Bar (1/8)	491718-003
Throat Plate Knife Cutting Bar (5/32)	491718-010
Throat Plate Knife Cutting Bar (3/16)	491718-012
Throat Plate Knife Cutting Bar (1/4)	491718-016
Throat Plate Knife Cutting Bar (9/32)	491718-018
Throat Plate Knife Cutting Bar (5/16)	491718-020
Throat Plate Knife Cutting Bar (3/8)	491718-024
Lifting Presser Foot (1/8 & 5/32)	491727-003
Lifting Presser Foot (3/16)	491727-012
Lifting Presser Foot (1/4)	491727-016
Lifting Presser Foot (9/32 & 5/16)	491727-018
Lifting Presser Foot (3/8)	491727-024
Needle (#126 x 11)	4506-211

PART NO.	DESCRIPTION	IN STOCK	MADE FROM SINGER PART	SINGER PART IN STOCK	BACK
223905	TENSION				
235576	" RELEASE PIN				
227561	FOOT LIFTER LEVER SPRING				
200029	SCREW				
494230-001	SCREW				
494997-001	III G117				
492065-001	FEED DRIVE ROCK SHAFT CRANK				
492065-002	THROAT PLATE BODY		240401		
492065-003	N.B. ROCK FRAME CRANK				
492065-006	P.B. LIFTING BRACKET		264526		
492065-007	INSERT				
491717-001	V. PRESSER FOOT $\frac{1}{8}$ " - $\frac{5}{32}$ "		240496		
491717-002	" " " $\frac{3}{16}$ " - $\frac{3}{8}$ "		240497		
491718-008	CUTTING BAR $\frac{1}{8}$ "		240384		
491718-010	" " $\frac{5}{32}$ "		240481		
491718-012	" " $\frac{3}{16}$ "		240483		
491718-016	" " $\frac{1}{4}$ "		240421		
491718-018	" " $\frac{9}{32}$ "		240488		
491718-020	" " $\frac{5}{16}$ "		240490		
491718-024	" " $\frac{3}{8}$ "		240494		
491727-008	L: PRESSER FOOT $\frac{1}{8}$ " - $\frac{5}{32}$ "		240472		
491727-012	" " " $\frac{3}{16}$ "		240473		
491727-016	" " " $\frac{1}{4}$ "		240474		
491727-018	" " " $\frac{9}{32}$ " - $\frac{5}{16}$ "		240475		
491727-024	" " " $\frac{3}{8}$ "		240476		
491716-001	FEED DOG $\frac{1}{8}$ " - $\frac{5}{32}$ "		240456		
491716-002	" " $\frac{3}{16}$ " - $\frac{3}{8}$ "		240457		

REVISIONS

SYM.	DESCRIPTION	CHG'D BY	CHK'D BY	DATE
A	ADDED CHART	W.F.C.		7-21-65
B	ADDED .030 X .025 GROOVE	A.K.S.		8-15-67

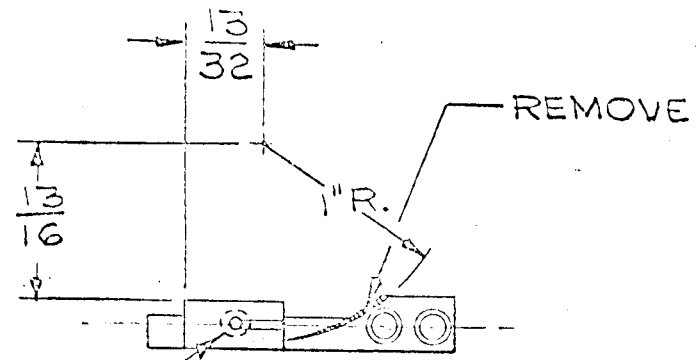

1/16 R. ALL AROUND
(OPPOSITE SIDE)

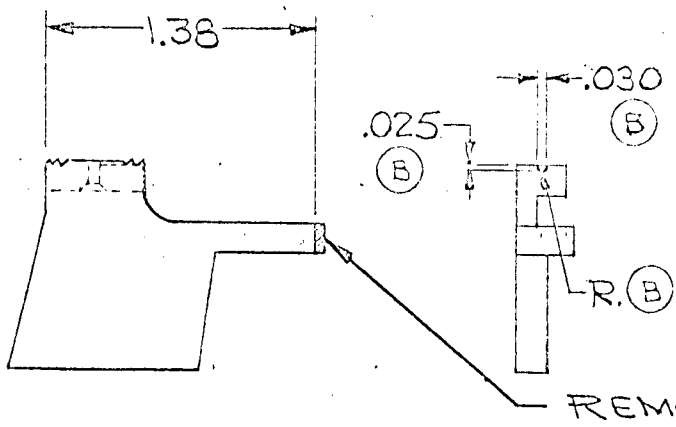

DWG. NO.	MATERIAL	CAGE
491716-001	240456	1/3
491716-002	240457	5/32 TO 2/3

ITEM NO.	REQ'D.	DESCRIPTION	DWG. OR CAT. NO.
----------	--------	-------------	------------------

NAME		FEED DOG , IIIW117			PROJECT NUMBER	
MATERIAL		SEE CHART			THE SINGER COMPANY INDUSTRIAL PRODUCTS DIVISION MECHANIZED SYSTEMS DEPARTMENT	
HEAT TREATMENT					DRAWING NUMBER	
FINISH					491716	
TOLERANCE UNLESS OTHERWISE SPECIFIED		DATE OF ISSUE			JUL 27 1965	
MAL: 2 PLACES ± .010 3 PLACES ± .005		FRACTIONS: ± 1/64			ALL EDGES BROKEN .005 - .010	

491717

REVISIONS

SYM.	DESCRIPTION	CHG'D BY	CHK'D BY	DATE
A ₂	REDIMENSIONED; REMOVED .11 R WAS 3/16 APPROX.	N.C.	W.F.C.	10/15/65
B	ADDED CHART & TWO VIEWS WITH DIMS.	W.F.C.		10/15/65
C	CHG'D. MATERIAL TO SEE CHART	W.F.C.		10/15/65

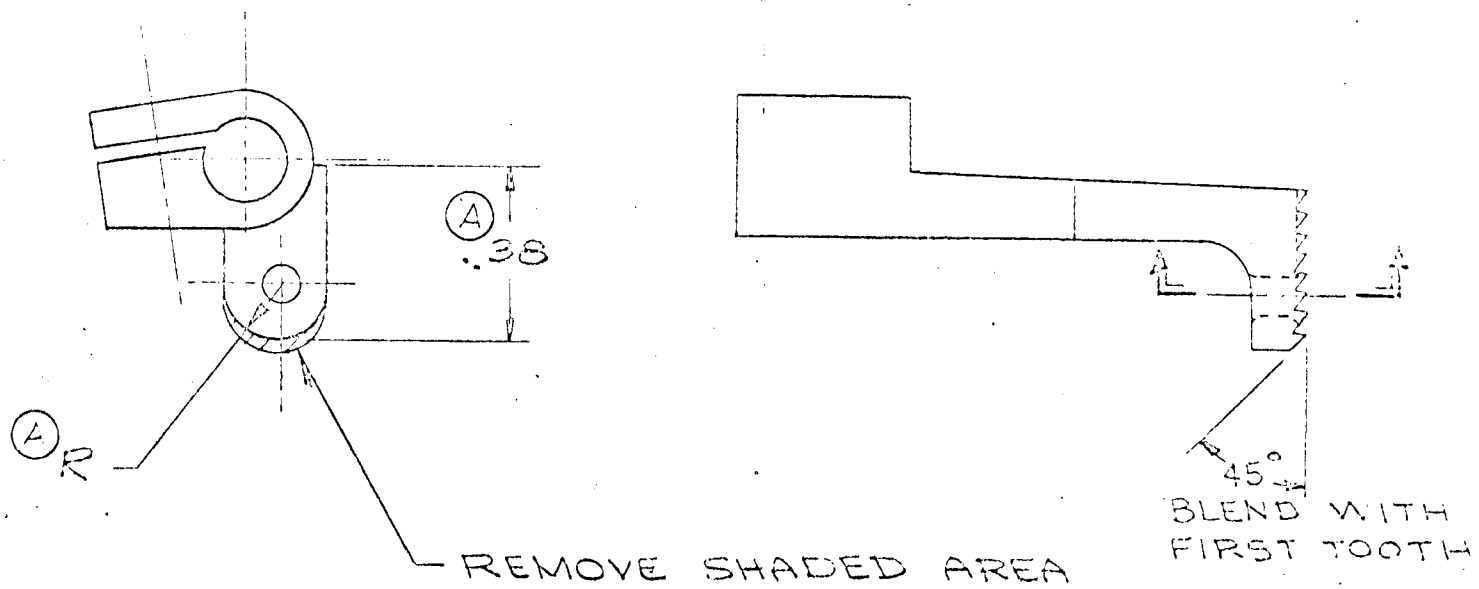

DWG. NO.	MATERIAL	GAGA
91717-001	240496	1/8 & 5/32
91717-002	240497	3/16 TO 3/8

ITEM NO.	REQ'D.	DESCRIPTION	DWG. OR CAT. NO.
----------	--------	-------------	------------------

NAME	VIBRATING PRESSER FOOT, IIIW117		
MATERIAL	SEE CHART	DRAWN BY	N.C.
HEAT TREATMENT		DATE DRAWN	7-22-65
FINISH		SCALE	2:1
USED ON		CHECKED BY	W.F.C.
		ENG. APPR.	1/11
		MFG. APPR.	

PROJECT NUMBER
 THE SINGER COMPANY
 INDUSTRIAL PRODUCTS DIVISION
 MECHANIZED SYSTEMS DEPARTMENT
 DRAWING NUMBER

TOLERANCE UNLESS OTHERWISE SPECIFIED
 DIMS: 2 PLACES ± .010
 3 PLACES ± .005
 FRACTIONS: ± 1/64
 ANGLES: ±
 ALL EDGES BROKEN
 .005 - .010

DATE OF ISSUE
 OCT 27 1965

491717

491718

REVISIONS

SYM.	DESCRIPTION	CHK'D BY	CHK'D BY	DATE
A	ADDED TABLE			1/2/65

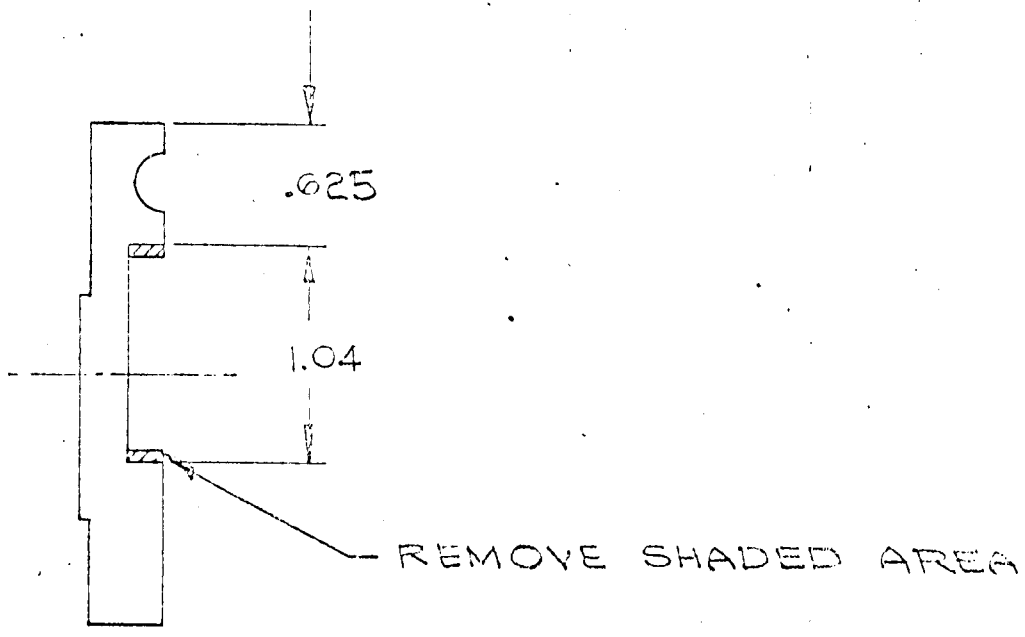

491718001	18	3-10-64
491718000	1/16	3-10-64
491718018	1/16	3-10-65
491718016	1/16	3-10-64
491718012	1/16	3-10-64
491718010	1/16	3-10-64
491718008	18	3-10-64
PART NO	18	3-10-64

ITEM NO.	REQ'D.	DESCRIPTION	DWG. OR CAT. NO.
----------	--------	-------------	------------------

NAME	THROAT PLATE KNIFE CUTTING BAR			IIIW117	PROJECT NUMBER	
MATERIAL		DRAWN BY	N.C.	CHECKED BY	W.F.C.	THE SINGER COMPANY INDUSTRIAL PRODUCTS DIVISION MECHANIZED SYSTEMS DEPARTMENT DRAWING NUMBER 491718
HEAT TREATMENT		DATE DRAWN	7-22-65	ENG. APPR.	1/1	
USED ON		SCALE	1:1	MFG. APPR.		
FINISH		DATE OF ISSUE	10/24/65			
TOLERANCE UNLESS OTHERWISE SPECIFIED						
DECIMAL: 2 PLACES ± .010 3 PLACES ± .005	FRACTIONS: ± 1/64	ANGLES: ±	ALL EDGES DROKEN .005 - .010			

491727

REVISIONS

SYM.	DESCRIPTION	CHG'D BY	CHG'D NO.	DATE
------	-------------	----------	-----------	------

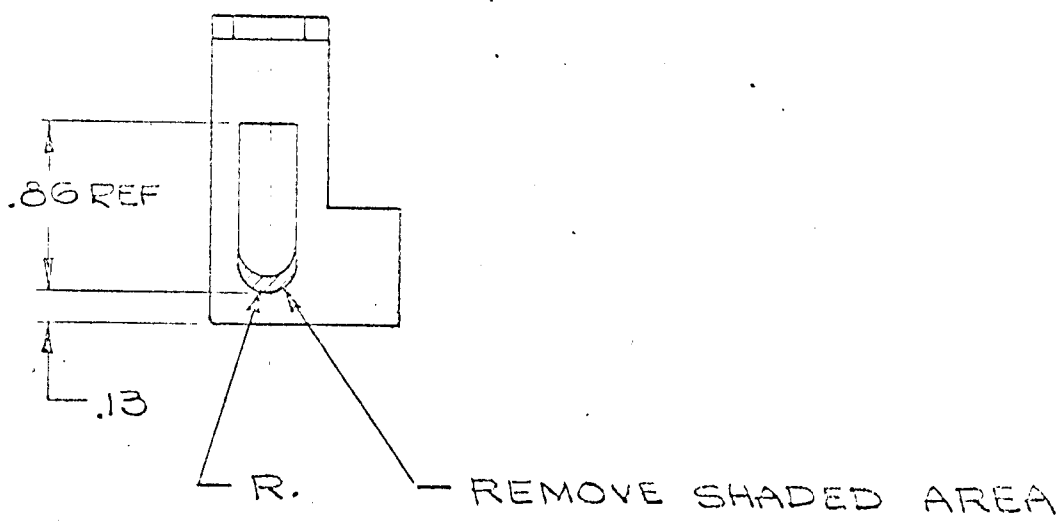

491727004	7	1-20-47
491727015	12	1-20-47
491727016	14	1-20-47
491727012	116	1-20-47
491727008	15	1-20-47
PART NO		

ITEM NO.	REQ'D.	DESCRIPTION	DWG. OR CAT. NO.
----------	--------	-------------	------------------

NAME	LIFTING PRESSER FOOT , IIIW117				
MATERIAL	SEE CHART				
HEAT TREATMENT		DRAWN BY	N.C.	CHECKED BY	W.F.C.
FINISH		DATE DRAWN	7-22-65	ENG. APPR.	1/11
USED ON		SCALE	1:1	MFG. APPR.	

PROJECT NUMBER
THE SINGER COMPANY
 INDUSTRIAL PRODUCTS DIVISION
 MECHANIZED SYSTEMS DEPARTMENT
 DRAWING NUMBER

TOLERANCE UNLESS OTHERWISE SPECIFIED	ALL EDGES BROKEN .005 - .010
DECIMAL: 2 PLACES ± .010 3 PLACES ± .005	FRACTIONS: ± 1/64 ANGLES: ±

DATE OF ISSUE

491727

492065-001

REVISIONS

SYM.	DESCRIPTION	CHG'D BY	CHK'D BY	DATE
C	REDRAWN WITH CHANGES	RML		
D	ADDED NOTE #1	JIK		
E	REMD. DIMS. 28 DIA & .970	RHC		

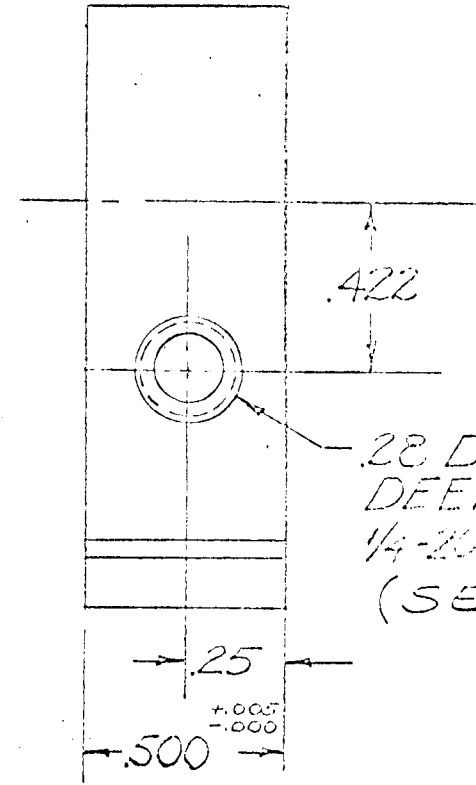
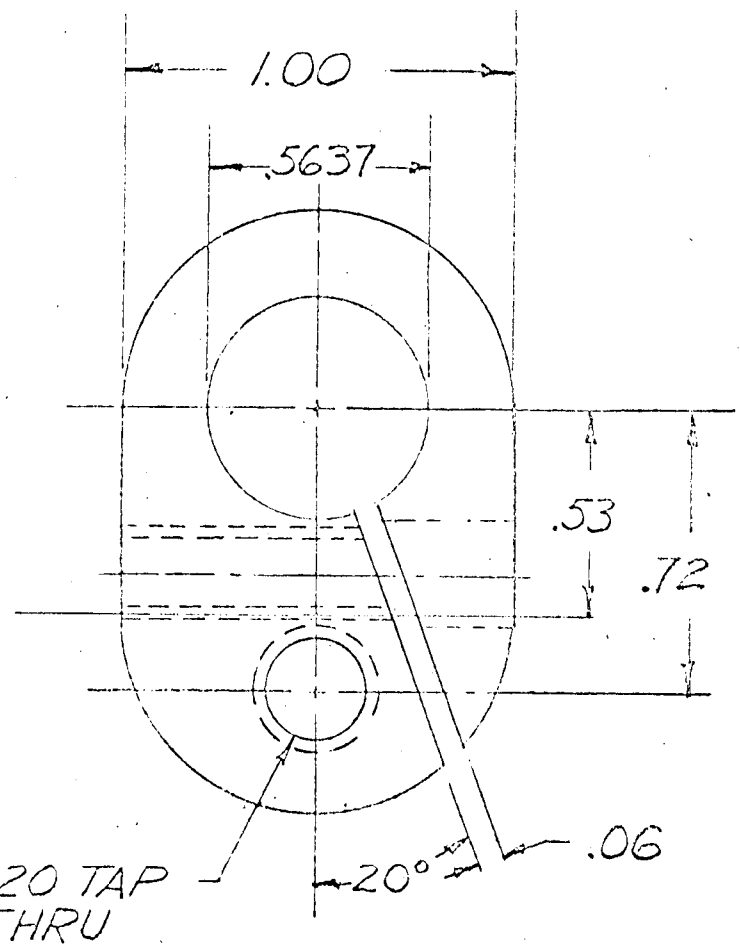

28 DIA. C'BORE x .25 DEEP. DRILL & TAP 1/4-20 THD THRU (SEE NOTE)

5/16 -20 TAP THRU

20° .06

NOTE:
 1- ASSEMBLE SCREW, FIL. HD. #1/4-20 x 1" LG.
 2- BEFORE STOCKING PART

OLD NO MSD 1554

ITEM NO.	REQ'D.	DESCRIPTION	DWG. OR CAT. NO.
		FEED DRIVING ROCK SHAFT CRANK	PROJECT NUMBER
		MATERIAL: STEEL	THE SINGER COMPANY INDUSTRIAL PRODUCTS DIVISION MECHANIZED SYSTEMS DEPARTMENT
		HEAT TREATMENT	DRAWING NUMBER
385-113		FINISH: BLACK OXIDE	492065-001
USED ON		TOLERANCE UNLESS OTHERWISE SPECIFIED	
		DECIMAL: 2 PLACES ± .010 3 PLACES ± .005	
		FRACTIONS: ± 1/64	
		ANGLES: ±	
		ALL EDGES BROKEN .005 - .010	
		DATE OF ISSUE	

REVISIONS

SYM.	DESCRIPTION	CHG'D BY	CHK'D BY	DATE
------	-------------	----------	----------	------

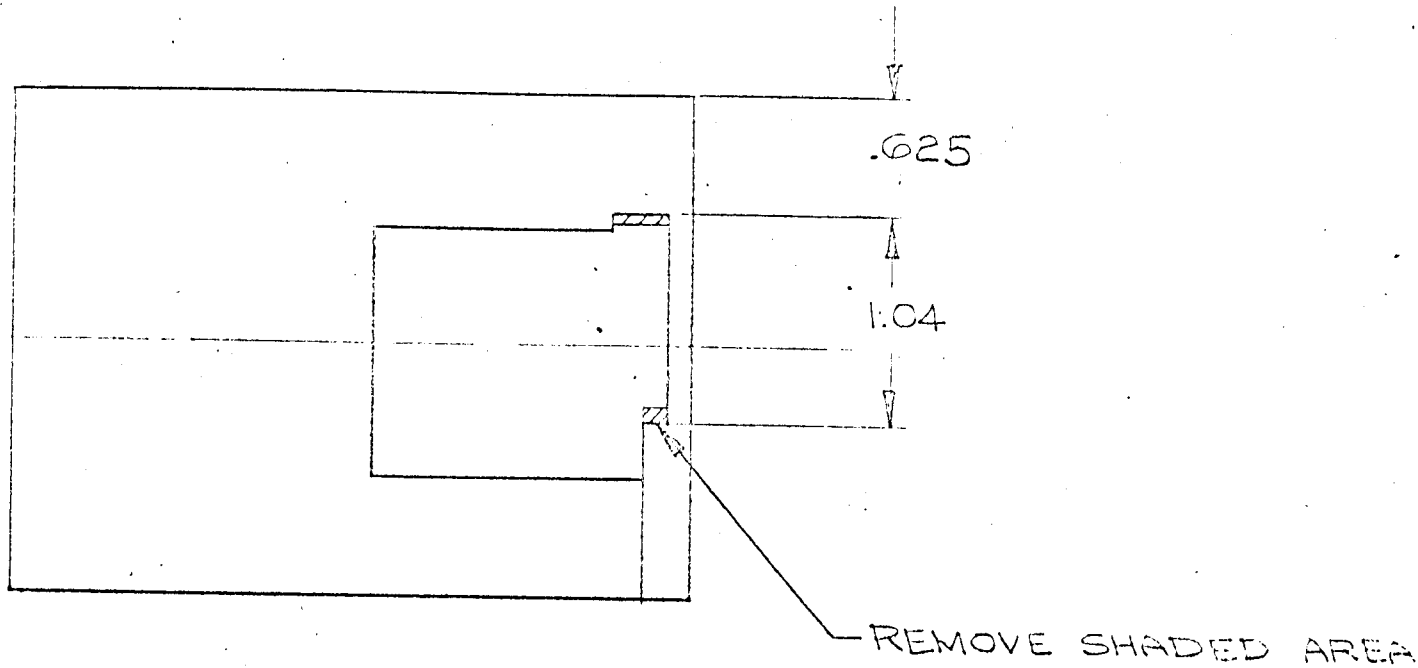

ITEM NO.	REQ'D.	DESCRIPTION	DWG. OR CAT. NO.
----------	--------	-------------	------------------

NAME		THROAT PLATE BODY IIIW117				PROJECT NUMBER	
MATERIAL		240401		DRAWN BY	N.C	CHECKED BY	W.F.C.
HEAT TREATMENT				DATE DRAWN	7-22-65	ENG. APPR.	P.H.
FINISH				SCALE	1:1	MFG. APPR.	
TOLERANCE UNLESS OTHERWISE SPECIFIED							
DECIMAL: 2 PLACES ± .010		FRACTIONS: ± 1/64		ANGLES: ±		ALL EDGES BROKEN .005 - .010	
3 PLACES ± .005				DATE OF ISSUE		001 21 015	
USED ON						DRAWING NUMBER	
						422005-002	

REVISIONS

SYM.	DESCRIPTION	CHG'D BY	CHG'D BY	DATE
A	REDRAWN WITH CHANGES FOR 10/20/69			
B	ADDED NOTE #1	DTC		7/23/69

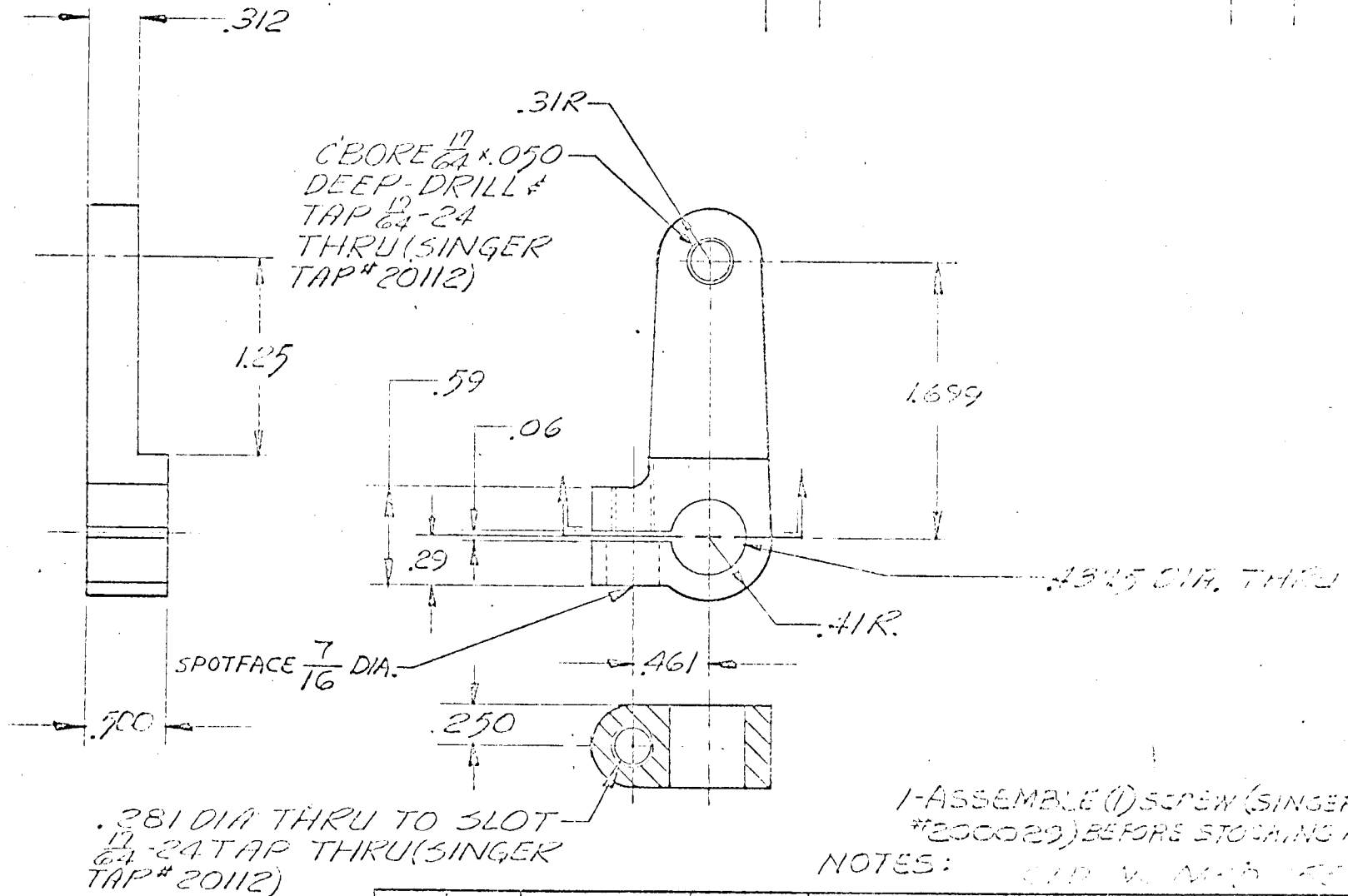

ITEM NO.	REQ'D.	DESCRIPTION	DWG. OR CAT. NO.
----------	--------	-------------	------------------

NAME	NEEDLE BAR ROCK FRAME ROCK SHAFT CRANK, IIIW117		
MATERIAL	STEEL		
HEAT TREATMENT		DRAWN BY	NOM
		DATE DRAWN	7-23-69
FINISH	BLACK OXIDE	CHECKED BY	WPC
		ENG. APPR.	
		MFG. APPR.	
		SCALE	1-1

PROJECT NUMBER	
THE SINGER COMPANY INDUSTRIAL PRODUCTS DIVISION MECHANIZED SYSTEMS DEPARTMENT	
DRAWING NUMBER	

TOLERANCE UNLESS OTHERWISE SPECIFIED			
DECIMAL: 2 PLACES ± .010 3 PLACES ± .005	FRACTIONS: ± 1/64	ANGLES: ±	ALL EDGES BROKEN .005 - .010
DATE OF ISSUE			

148065 003

REVISIONS

SYM.	DESCRIPTION	CHK'D BY	CHK'D BY	DATE
A2	REDIMENSIONED; REMOVED .15" R. WAS 5/16" R. ADDED 2.75	NOM	W.F.C.	11/1/65

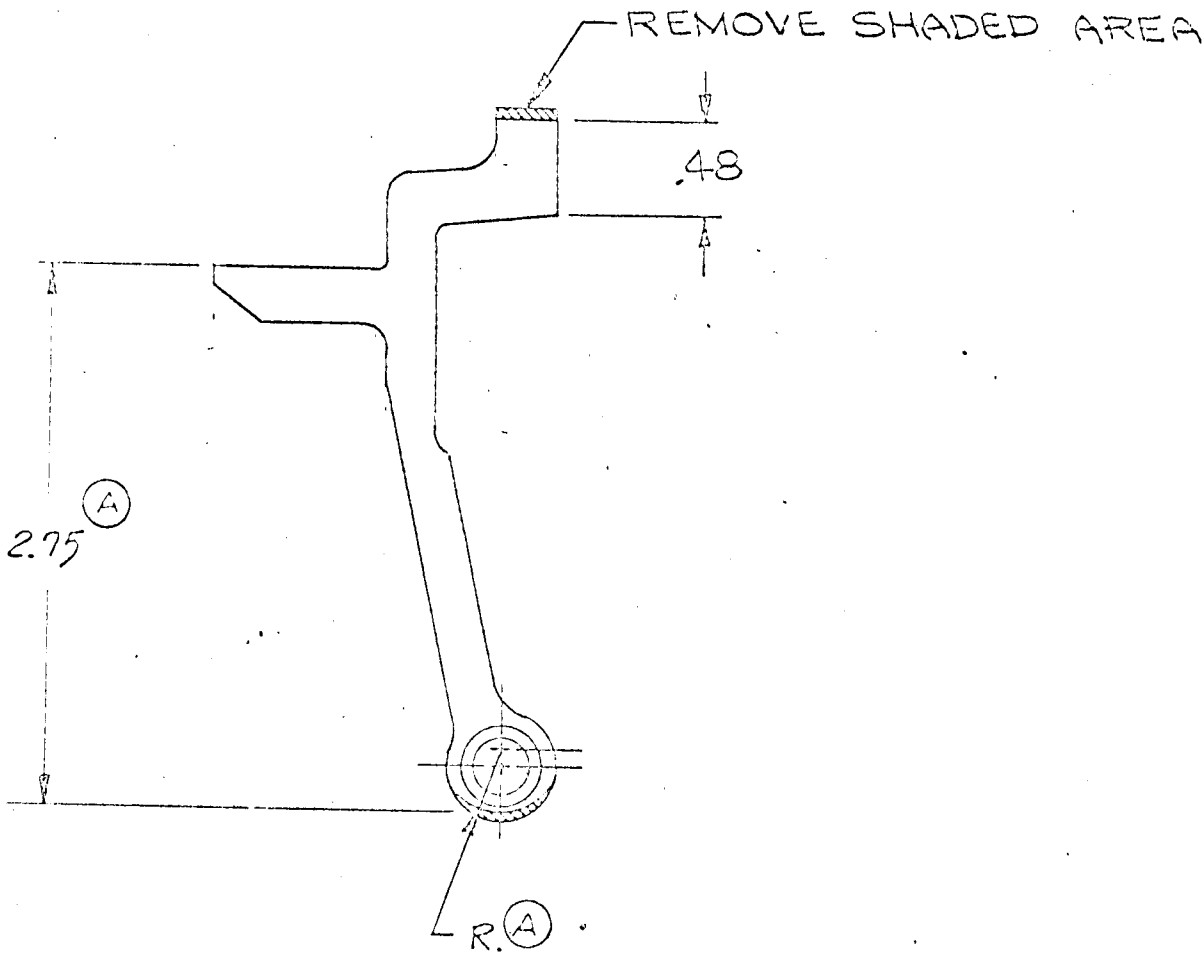

ITEM NO.	REQ'D.	DESCRIPTION	DWG. OR CAT. NO.
----------	--------	-------------	------------------

NAME		FEED BAR, IIIW117				PROJECT NUMBER	
MATERIAL		240454		DRAWN BY	W.F.C.	CHECKED BY	W.F.C.
HEAT TREATMENT				DATE DRAWN	7-23-65	ENG. APPR.	
FINISH				SCALE	1:1	MFG. APPR.	
TOLERANCE UNLESS OTHERWISE SPECIFIED							
ALL: 2 PLACES ± .010 3 PLACES ± .005		FRACTIONS: ± 1/64		ANGLES: ±		ALL EDGES BROKEN .005 - .010	
				DATE OF ISSUE	OCT 21 1965		
DRAWING NUMBER 132065 001							

REVISIONS

SYM.	DESCRIPTION	CHG'D BY	CHK'D BY	DATE
A	REDIMENSIONED LOCATION OF SLOT: DELETED .455 DIM	NOMI	H.F.C.	10-25-67

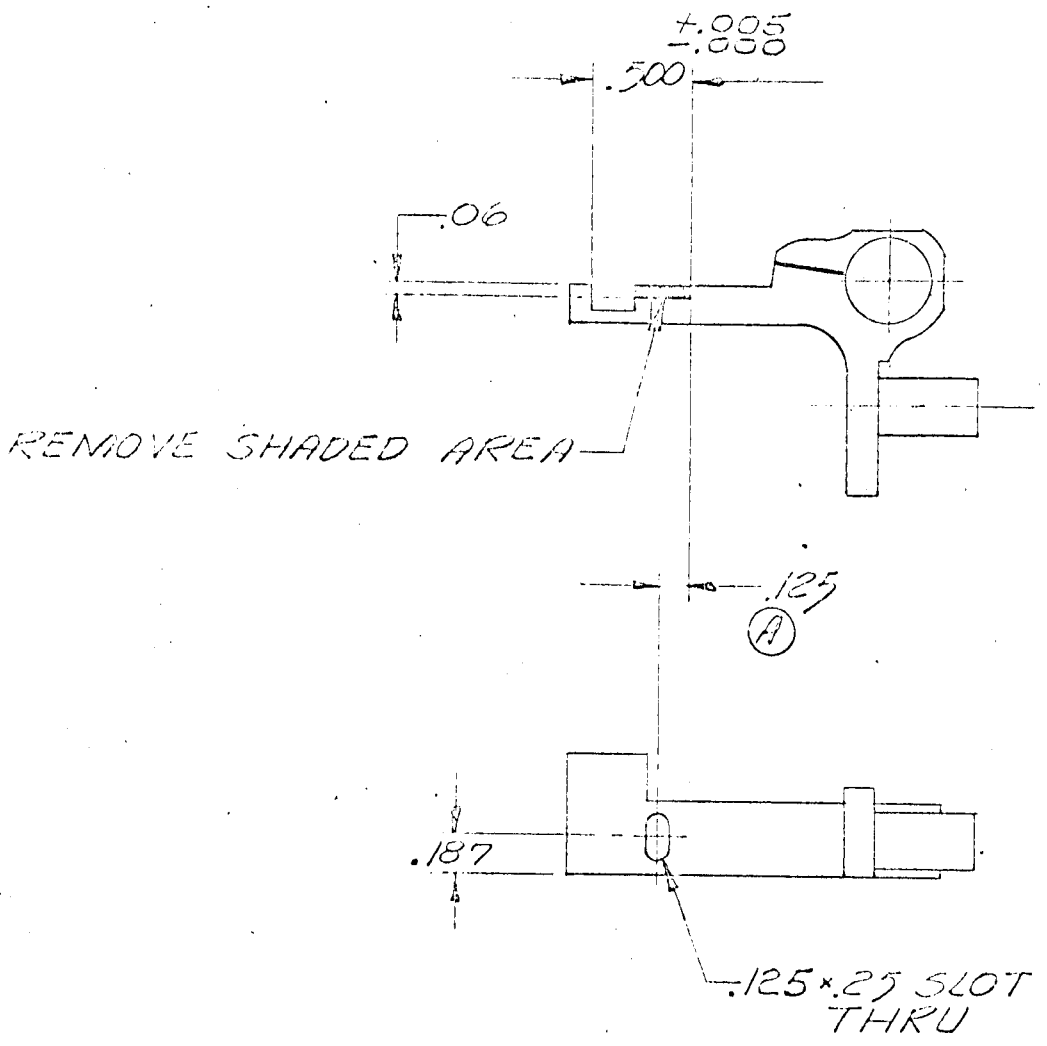

ITEM NO.	REQ'D.	DESCRIPTION	DWG OR CAT NO
----------	--------	-------------	---------------

NAME	PRESSER BAR LIFTING BRACKET			PROJECT NUMBER	
MATERIAL	264526	DRAWN BY	NOMI	CHECKED BY	H.F.C.
HEAT TREATMENT		DATE DRAWN	10-25-67	ENG. APPR.	
USED ON	FINISH	SCALE	1-1	MFG. APPR.	

THE SINGER COMPANY
INDUSTRIAL PRODUCTS DIVISION
MECHANIZED SYSTEMS DEPARTMENT

DRAWING NUMBER

TOLERANCE UNLESS OTHERWISE SPECIFIED			DATE OF ISSUE	4204-000
CIMAL: 2 PLACES ± .010 3 PLACES ± .005	FRACTIONS: ± 1/64	ANGLES: ±	ALL EDGES BROKEN .005 - .010	

REVISIONS

SYM.	DESCRIPTION	CHGD BY	CHK'D BY	DATE
A	ADDED NOTE #1	W.F.C.		

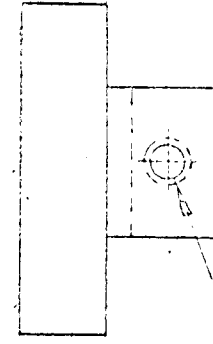
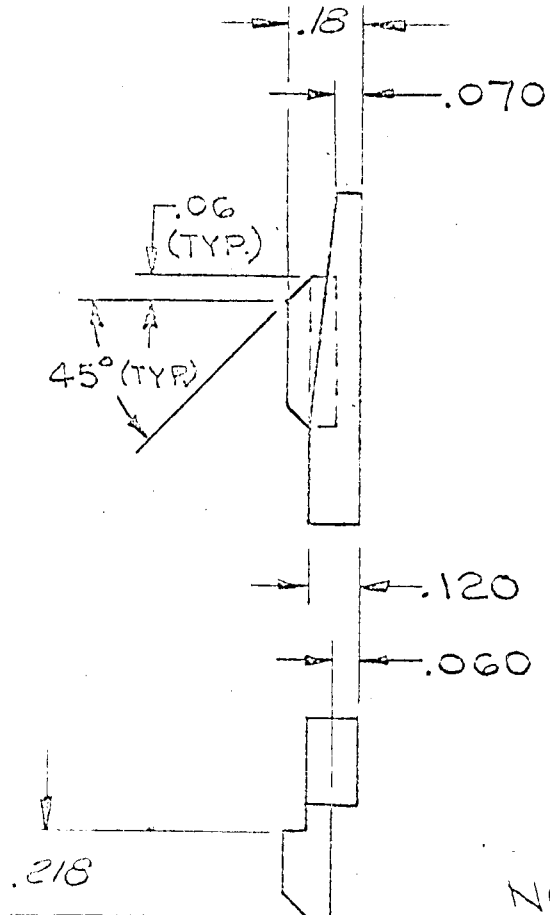
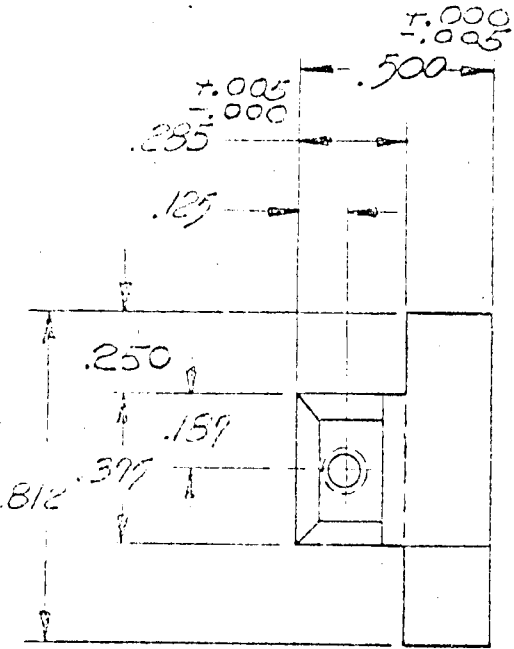

#4-40 THRU

1- ASSEMBLE (1) SCREW, CAP, HEX. SKT. #4-40 x 1/4 LG. BEFORE STOCKING PART.

NOTES:-

OLD NO. 4-11-13-1

ITEM NO.	REQ'D.	DESCRIPTION	DWG. OR CAT. NO.
		ACTUATOR FINGER INSERT (IIIW117)	
NAME		ACTUATOR FINGER INSERT (IIIW117)	PROJECT NUMBER
MATERIAL		STEEL	THE SINGER COMPANY INDUSTRIAL PRODUCTS DIVISION MECHANIZED SYSTEMS DEPARTMENT
HEAT TREATMENT			
FINISH		BLACK OXIDE	
DRAWN BY		NOMI	DRAWING NUMBER
DATE DRAWN		10-20-67	
CHECKED BY		W.F.C.	DATE OF ISSUE
SCALE		2-1	
TOLERANCE UNLESS OTHERWISE SPECIFIED			
DECIMAL: 2 PLACES ± .010 3 PLACES ± .005		FRACTIONS: ± 1/64	
ANGLED: ±		ALL EDGES BROKEN .005 - .010	

NOV 27 1968

4-22067-001

REVISIONS

SYM.	DESCRIPTION	CHK'D BY	CHK'D DATE
------	-------------	----------	------------

REMOVE SHADED AREA

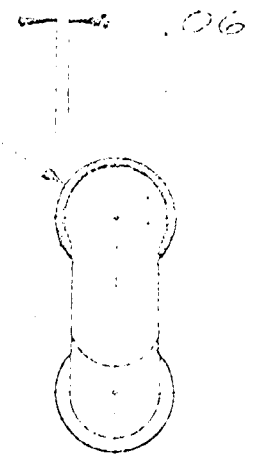
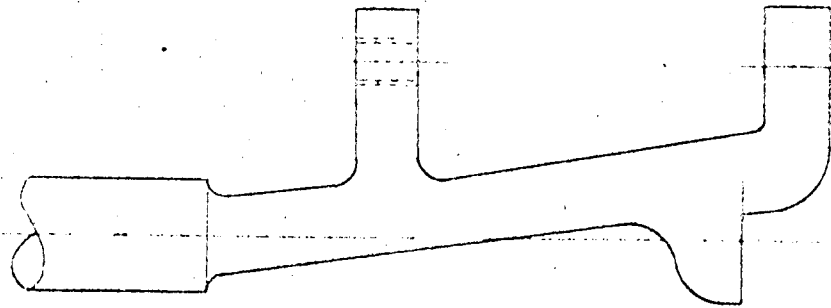

ITEM NO.		REQ'D.	DESCRIPTION			DWG. OR CAT. NO.
NAME		FEED DRIVING ROCK SHAFT			PROJECT NUMBER	
MATERIAL		223 650			THE SINGER COMPANY INDUSTRIAL PRODUCTS DIVISION MECHANIZED SYSTEMS DEPARTMENT	
HEAT TREATMENT					DRAWING NUMBER	
FINISH					4920657-000	
USED ON					DATE OF ISSUE	
TOLERANCE UNLESS OTHERWISE SPECIFIED						
DIMALS: 2 PLACES ± .010		FRACTIONS: ± 1/64		ANGLES: ±		ALL EDGES BROKEN .005 - .010
3 PLACES ± .005						